



Translation of the Original Operating Manual

Tiger
72-300

Version 01/2013

IceBreaker Piston Pump
Flow Rate 300 cm³

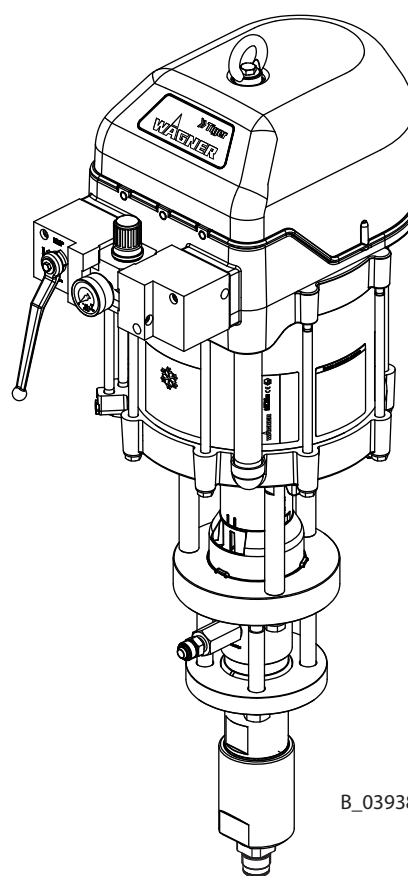

B_03938



II 2G IIB c T3 X

Contents

1	ABOUT THESE INSTRUCTIONS	5
1.1	Preface	5
1.2	Warnings, Notices and Symbols in these Instructions	5
1.3	Languages	6
1.4	Abbreviations in the Text	6
2	CORRECT USE	7
2.1	Device Types	7
2.2	Type of Use	7
2.3	Use in an Explosion Hazard Area	7
2.4	Safety Parameters	7
2.5	Processible Materials	8
2.6	Reasonably Foreseeable Misuse	8
2.7	Residual Risks	9
3	IDENTIFICATION	10
3.1	Explosion Protection Identification	10
3.2	Identification X	10
4	GENERAL SAFETY INSTRUCTIONS	11
4.1	Safety Instructions for the Operator	11
4.1.1	Electrical Equipment	11
4.1.2	Personnel Qualifications	11
4.1.3	Safe Work Environment	11
4.2	Safety Instructions for Staff	12
4.2.1	Safe Handling of WAGNER Spray Devices	12
4.2.2	Grounding the Device	13
4.2.3	Material Hoses	13
4.2.4	Cleaning	14
4.2.5	Handling Hazardous Liquids, Varnishes and Paints	14
4.2.6	Touching Hot Surfaces	14
4.3	Use in Areas Subject to Explosion Hazards	15
4.3.1	Safety Regulations	15
4.3.2	Operation without Fluid	15
5	DESCRIPTION	16
5.1	Areas of Application	16
5.1.1	Correct Use	16
5.1.2	Processible Materials	16
5.1.3	Recommended Application Areas	16
5.2	Scope of Delivery	17
5.3	Data	17
5.3.1	Materials of Paint-wetted Parts	17
5.3.2	Recommended Packings	18
5.3.3	Technical Data	19
5.3.4	Measurements and Connections	20
5.3.5	Volume Flow	21
5.3.6	Performance Diagrams	22

5.4	Function	23
5.4.1	Pump	23
5.4.2	Pressure Regulator Unit	24
5.4.3	High-pressure Filter (Option)	25
5.4.4	Stroke Count (Option)	25
6	ASSEMBLY AND COMMISSIONING	26
6.1	Transportation	26
6.2	Storage	26
6.3	Assembling the Pump	27
6.4	Grounding	28
6.5	Commissioning	30
6.5.1	Safety Instructions	30
6.5.2	Filling with Separating Fluid	31
6.5.3	Basic Flushing	32
7	OPERATION	33
7.1	Filling with Working Material	33
7.2	Work	33
7.2.1	Spraying	33
7.2.2	Pressure Relief / Work Interruption	33
7.2.3	Decommissioning and Cleaning	34
7.3	Long-term Storage	34
8	TROUBLE SHOOTING AND RECTIFICATION	35
8.1	Trouble Shooting and Rectification	35
9	MAINTENANCE	36
9.1	High-pressure Hoses	37
9.2	Decommissioning	37
10	ACCESSORIES	38
10.1	Material Outlet Accessories	38
10.2	Material Inlet Accessories	40
10.3	Trolley and Wall Bracket Accessories	42
11	SPARE PARTS	43
11.1	How Can Spare Parts Be Ordered?	43
11.2	Overview of Components	44
11.3	Air Motor	45
11.3.1	Tiger Air Motor	45
11.3.2	Tiger Air Motor Regulator	49
11.4	Fluid Section 300 cm ³	50
11.5	"Heavy Duty" Trolley	53
11.6	High-pressure Filter (up to 530 bar; 7687 psi)	54
12	GUARANTEE AND CONFORMITY DECLARATIONS	56
12.1	Important Notes Regarding Product Liability	56
12.2	Warranty Claim	56
12.3	CE Declaration of Conformity	57
12.4	Reference to German Regulations and Guidelines	57

1 ABOUT THESE INSTRUCTIONS

1.1 PREFACE

The operating manual contains information about safely operating, maintaining, cleaning and repairing the device.

The operating manual is part of the device and must be available to operating and service staff.

Operating and service personnel should be instructed according to the safety instructions.



The device may only be operated in compliance with this operating manual.

This equipment can be dangerous if it is not operated according to the definitions in this operating manual.



1.2 WARNINGS, NOTICES AND SYMBOLS IN THESE INSTRUCTIONS

Warning instructions in this operating manual highlight particular dangers to users and device and state measures for avoiding the hazard. These warning instructions fall into the following categories:



Danger - immediate risk of danger.
Non-observance will result in death or serious injury.

	 DANGER
	<p>This information warns you of a hazard! Possible consequences of not observing the warning instructions. The signal word indicates the hazard level.</p> <p>→ The measures for preventing the hazard and its consequences.</p>

Warning - possible imminent danger.
Non-observance may result in death or serious injury.

	 WARNING
	<p>This information warns you of a hazard! Possible consequences of not observing the warning instructions. The signal word indicates the hazard level.</p> <p>→ The measures for preventing the hazard and its consequences.</p>

Caution - a possibly hazardous situation.
Non-observance may result in minor injury.

	 CAUTION
	<p>This information warns you of a hazard! Possible consequences of not observing the warning instructions. The signal word indicates the hazard level.</p> <p>→ The measures for preventing the hazard and its consequences.</p>

Notice - a possibly hazardous situation.
Non-observance may result in material damage.

NOTICE
<p>This information warns you of a hazard! Possible consequences of not observing the warning instructions. The signal word indicates the hazard level.</p> <p>→ The measures for preventing the hazard and its consequences.</p>

Note - provides information about particular characteristics and how to proceed.

1.3 LANGUAGES

The operating manual is available in the following languages:

Language	Order No.	Language	Order No.
German	2333542	English	2333543
French	2333544	Spanish	2333546
Italian	2333545		

The corresponding service instructions are available under the following order number:

Language	Order No.	Language	Order No.
German	2335993	English	2335994

1.4 ABBREVIATIONS IN THE TEXT

Stk	Number of pieces
Pos	Position
K	Marking in the spare parts lists
Order No.	Order number
DH	Double stroke
SSt	Stainless steel
2K	Two components

2 CORRECT USE

2.1 DEVICE TYPES

Pneumatic pump with spraypack:

Tiger
72-300

2.2 TYPE OF USE

The device is suitable for processing liquid materials like paints and varnishes in accordance with the classification into explosion classes IIA or IIB.

2.3 USE IN AN EXPLOSION HAZARD AREA

The pneumatic pump can be employed in explosion hazard zones (Zone 1).



2.4 SAFETY PARAMETERS

WAGNER accepts no liability for any damage arising from incorrect use.

- Use the device only to work with the materials recommended by WAGNER.
- Only operate the device as a whole.
- Do not deactivate safety fixtures.
- Use only WAGNER original spare parts and accessories.



The pneumatic pump may only be operated under the following conditions:

- The operating staff must be trained on the basis of this operating manual.
- The safety regulations listed in this operating manual must be observed.
- The operating, maintenance and repair information in this operating manual must be observed.
- The statutory requirements and accident prevention regulation standards in the country of use must be observed.

2.5 PROCESSIBLE MATERIALS

- Fluid materials like paints and varnishes.

NOTICE

Abrasive materials and pigments!

Greater wear of parts carrying the material.

- Use the application-oriented model (flow rate/cycle, material, valves, etc.) as indicated in Chapter 5.3.3.
- Check if the fluids and solvents used are compatible with the pump construction materials as indicated in Chapter 5.3.1.

2.6 REASONABLY FORESEEABLE MISUSE

The following is prohibited:

- coating work pieces which are not grounded,
- unauthorized conversions and modifications to the pneumatic pump,
- processing dry or similar coating materials, and
- using defective components, spare parts or accessories other than those described in chapter 10 of this operating manual.

The forms of misuse listed below may result in health issues and/or equipment damage:

- use of powder as coating material and
- incorrectly set values for processing.

Wagner pneumatic pumps are not designed for pumping food.

2.7 RESIDUAL RISKS

Residual risks are risks which cannot be excluded even in the event of correct use.

If necessary, warning and prohibition signs at the relevant points of risk indicate residual risks.

Residual risk	Source	Consequences	Specific measures	Lifecycle phase
Skin contact with paints and cleaning agents	Handling of paints and cleaning agents	Skin irritations, allergies	Wear protective clothing Observe safety data sheets	Operation, maintenance, disassembly
Paint in air outside the defined working area	Painting outside the defined working area	Inhalation of substances which are hazardous to health	Observe working and operating instructions.	Operation, maintenance

3 IDENTIFICATION

3.1 EXPLOSION PROTECTION IDENTIFICATION

As defined in the Directive 94/9/EC (ATEX 95), the device is suitable for use in areas where there is an explosion hazard.



CE  II 2G IIB c T3 X

CE: European Communities

Ex: Symbol for explosion protection

II: Device class II

2: Category 2 (Zone 1)

G: Ex-atmosphere gas

IIB: Explosion group

c: Constructional security

T3: Temperature class: maximum surface temperature < 200 °C; 392 °F

X: Special Notes (see Chapter 3.2).

3.2 IDENTIFICATION X

Maximum surface temperature

The maximum surface temperature of the piston pump can be reached if it runs dry.

→ Ensure that the piston pump is filled with sufficient working or flushing agent.

→ Ensure that the separating agent container is filled with sufficient separating agent.

Ignition temperature of the coating material

→ Ensure that the ignition temperature of the coating material is above the maximum surface temperature.

Ambient temperature

→ The permissible ambient temperature is: +5 °C to +60 °C; +41 °C to 140 °F.

Medium supporting atomizing

→ To atomize the material, use only weakly oxidizing gases, e.g. air.

4 GENERAL SAFETY INSTRUCTIONS

4.1 SAFETY INSTRUCTIONS FOR THE OPERATOR

- Keep this operating manual at hand near the device at all times.
- Always follow local regulations concerning occupational safety and accident prevention.



4.1.1 ELECTRICAL EQUIPMENT

Electrical devices and equipment

- To be provided in accordance with the local safety requirements with regard to the operating mode and ambient influences.
- May only be maintained by skilled electricians or under their supervision.
- Must be operated in accordance with the safety regulations and electrotechnical regulations.
- Must be repaired immediately in the event of problems.
- Must be decommissioned if they pose a hazard.
- Must be de-energized before work is commenced on active parts. Inform staff about planned work. Observe electrical safety regulations.



4.1.2 PERSONNEL QUALIFICATIONS

- Ensure that the device is operated and repaired only by trained persons.

4.1.3 SAFE WORK ENVIRONMENT

- Ensure that the floor in the working area is electrically conductive in accordance with EN 61340-4-1 (resistance must not exceed 100 MOhm).
- Ensure that all persons within the working area wear electrostatically conductive shoes. Footwear must comply with EN 20344. The measured insulation resistance may not exceed 100 MOhm.
- Ensure that during spraying, persons wear electrically conductive gloves. The grounding takes place via the spray gun handle.
- If protective clothing is worn, including gloves, it has to comply with EN 1149-5. The measured insulation resistance may not exceed 100 MOhm.
- Paint mist extraction systems must be fitted on site according to local regulations.
- Ensure that the following components of a safe working environment are available:
 - Material/air hoses adapted to the working pressure.
 - Personal safety equipment (breathing and skin protection).
- Ensure that there are no ignition sources such as naked flames, sparks, glowing wires or hot surfaces in the vicinity. Do not smoke.

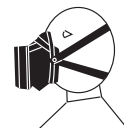

4.2 SAFETY INSTRUCTIONS FOR STAFF

- Always follow the information in these instructions, particularly the general safety instructions and the warning instructions.
- Always follow local regulations concerning occupational safety and accident prevention.



4.2.1 SAFE HANDLING OF WAGNER SPRAY DEVICES

The spray jet is under pressure and can cause dangerous injuries.

Avoid injection of paint or flushing agents:

- Never point the spray gun at people.
- Never reach into the spray jet.
- Before all work on the device, in the event of work interruptions and functional faults:
 - Switch off the energy/compressed air supply.
 - Relieve the pressure from the spray gun and device.
 - Secure the spray gun against actuation.

In the event of functional faults: remedy the fault as described in the "Trouble Shooting" chapter.

- The liquid ejection devices are to be checked for safe working conditions by an expert (e.g. Wagner Service Technician) as often as necessary or at least every 12 months, in accordance with the guidelines for liquid ejection devices (ZH 1/406 and BGR 500 Part 2 Chapter 2.36).
- For shut down devices, the examination can be suspended until the next start-up.
- Carry out the work steps as described in the "Pressure Relief / Work Interruptions" chapter:
 - if pressure relief is required.
 - if the spraying work is interrupted or stopped.
 - before the device is cleaned on the outside, checked or serviced.
 - before the spray nozzle is installed or cleaned.

In the event of skin injuries caused by paint or flushing agents:

- Note the paint or flushing agent that you have been using.
- Consult a doctor immediately.

Avoid danger of injury through recoil forces:

- Ensure that you have firm footing when operating the spray gun.
- Only hold the spray gun briefly in a position.

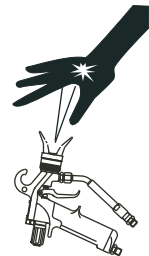

4.2.2 GROUNDING THE DEVICE

In order to avoid electrostatic charging of the device, the device must be grounded. Friction, flowing liquids and air or electrostatic coating processes create charges. Flames or sparks can form during discharge.

- Ensure that the device is grounded for every spraying operation.
- Ground the work pieces to be coated.
- Ensure that all persons inside the working area are grounded, e.g. that they are wearing electrostatically conductive shoes.
- Wear electrostatically conductive gloves when spraying. The grounding takes place via the spray gun handle.



4.2.3 MATERIAL HOSES

- Ensure that the hose material is chemically resistant to the sprayed materials.
- Ensure that the material hose is suitable for the pressure generated in the device.
- Ensure that the following information can be seen on the high pressure hose:
 - Manufacturer
 - Permissible operating overpressure
 - Date of manufacture.
- Make sure that the hoses are laid only in suitable places. In no case should hoses be laid in the following places:
 - in high traffic areas,
 - on sharp edges,
 - on moving parts or
 - on hot surfaces
- Make sure that the hoses are never used to pull or move the equipment.
- The electrical resistance of the complete high pressure hose must be less than 1 MOhm. Several liquids have a high expansion coefficient. In some cases their volume can rise with consequent damage to pipes, fittings, etc. and cause fluid leakage. When the pump sucks liquid from a closed container, ensure that air or suitable gas can enter the container to avoid a vacuum being generated in the container itself. Thus a negative pressure is avoided. The vacuum could cause the container to implode (squeeze) and to break. The container would leak and the liquid would flow out. The pressure created by the pump is a multiple of the inlet air pressure.



4.2.4 CLEANING

- De-energize the device electrically.
- Disconnect the pneumatic supply line.
- Relieve the pressure from the device.
- Ensure that the flash point of the cleaning agent is at least 5 K above the ambient temperature.
- To clean, use cloths and brushes moistened with solvent. Never use hard objects or spray on cleaning agents with a gun.
- Preferably, non-combustible cleaning agents should be used.

An explosive gas/air mixture forms in closed containers.

- When cleaning devices with solvents, never spray into a closed container.
- Only use electrically conductive containers for cleaning liquids.
- The containers must be grounded.



4.2.5 HANDLING HAZARDOUS LIQUIDS, VARNISHES AND PAINTS

- When preparing or working with paint and when cleaning the device, follow the working instructions of the manufacturer of the paints, solvents and cleaning agents being used.
- Take the specified protective measures. In particular, wear safety goggles, protective clothing and gloves, as well as hand protection cream if necessary.
- Use a mask or a breathing apparatus if necessary.
- For sufficient health and environmental safety: Operate the device in a spray booth or on a spraying wall with the ventilation (extraction) switched on.
- Wear suitable protective clothing when working with hot materials.



4.2.6 TOUCHING HOT SURFACES

- Touch hot surfaces only if you are wearing protective gloves.
- When operating the device with a coating material with a temperature of > 43 °C; 109 °F:
 - Identify the device with a warning sticker "Warning - hot surface".



Order No.

9998910 Instruction sticker

9998911 Protection sticker

Note: Order the two stickers together.

4.3 USE IN AREAS SUBJECT TO EXPLOSION HAZARDS

The pneumatic pump may be used in areas subject to explosion hazards. The following safety regulations must be observed and followed.



4.3.1 SAFETY REGULATIONS

Safe handling of WAGNER spray devices

Mechanical sparks can form if the device comes into contact with metal.

In an explosive atmosphere:

- Do not knock or push the device against steel or rusty iron.
- Do not drop the device.
- Use only tools that are made of a permitted material.



Ignition temperature of the pumped material

- Check that the ignition temperature of the pumped material is higher than the max. allowable surface temperature.

Medium supporting atomizing

- To atomize the material, use only weakly oxidizing gases, e.g. air.

Surface spraying, electrostatic

- Do not spray system parts with electrostatic.



Cleaning

If there are deposits on the surfaces, the device may form electrostatic charges. Flames or sparks can form during discharge.

- Remove deposits from the surfaces to maintain conductivity.
- Use only a damp cloth to clean the device.



4.3.2 OPERATION WITHOUT FLUID

Avoid running the pump sucking air, without fluid inside. The air, combined with the vapor of flammable fluids, can generate internal areas with an explosion hazard.

Periodically check that the pump is working regularly, paying special attention to the presence of air in the pumped fluid, which may be caused by damaged packings.

- Avoid operating the pump with damaged packing.
- Ensure that the separating agent container is filled with sufficient separating agent.

5 DESCRIPTION

5.1 AREAS OF APPLICATION

5.1.1 CORRECT USE

The pneumatic piston pump is suitable for processing liquid materials according to Chapter 5.1.2.

5.1.2 PROCESSIBLE MATERIALS

Application	Tiger 72-300
Water-dilutable materials	↗
Solvent based varnish and paints	↗
Primers	↗
Epoxy and polyurethane paints and varnish, phenolic paints and varnish	↗
Liquid plastics	↗
Wax based underside protection	↗
Chemically aggressive materials that attack carbide seats	↘

Legend

↗ recommended

↔ limited suitability

↘ less suitable

NOTICE

Abrasive materials and pigments!

Greater wear of parts carrying the material.

→ Use suitable combinations of devices (packings, valves etc.).

5.1.3 RECOMMENDED APPLICATION AREAS

Application	Tiger 72-300
Furniture industry	↘
Kitchen manufacturers	↘
Joinery	↘
Window factories	↘
Steel-processing industry	↗
Construction of vehicles	↔
Shipbuilding	↗

Legend

↗ recommended

↔ Schiffbaulimited suitability

↘ less suitable

5.2 SCOPE OF DELIVERY

Pneumatic piston pump

Consists of:

- Fluid section
- Air motor
- Connection elements
- Air pressure regulator for air motor

The scope of delivery also includes:

Separating agent 250 ml; 250 cc

Order No.: 9992504

Declaration of conformity

see Chapter 12

Operating manual, German

Order No.: 2333542

Operating manual in the local language

see Chapter 1

The delivery note shows the exact scope of delivery. Accessories: see Chapter 10.

5.3 DATA

5.3.1 MATERIALS OF PAINT-WETTED PARTS

Housing	Stainless steel
Piston	Stainless steel and hard chrome
Valve balls	Stainless steel
Valve seats	Carbide
O-ring	PTFE
Packings	Standard PE/L

PE = Ultra high molecular weight polyethylene

L = Leather

5.3.2 RECOMMENDED PACKINGS

WAGNER packings are manufactured in four different materials:

Code	Material	Color
L	Leather	dark brown
TG	PTFE with graphite	Black
PE	Ultra high molecular weight polyethylene	Transparent
T	PTFE	white

Each material has the following properties, which influence the packings:

	L	TG	PE	T
Mechanical stability	poor	good	good	poor
Friction coefficient	poor	very good	good	very good
Sealing force	good*	good	good	good
Chemical resistance	poor	good	very good	very good
Temperature resistance	good	poor - good	very good	poor

* for abrasive materials



Standard combinations

Heavy duty (high pressure) pumps: PE/L

5.3.3 TECHNICAL DATA

Description	Devices	Tiger 72-300
Pump ratio	-	72 :1
Volume flow per double stroke (DH)	cm ³ ; cc	300
Maximum operating pressure	MPa; bar; psi	53; 530; 7687
Maximum possible strokes in operation	DH/min	40
Maximum recommended strokes per minute in continuous operation	DH/min	30
Minimum / maximum air inlet pressure	MPa; bar; psi	0.25-0.74; 2.5-7.4; 36-107
Ø Air inlet (inside thread)	Zoll / inch	G 1"
Minimum Ø of the compressed air supply line	mm; inch	25; 1.0
Air consumption at 0.6 MPa; 6 bar; 87 psi per double stroke	nl; scf	170; 6
Air motor piston diameter	mm; inch	300; 11.8
Air motor piston stroke	mm; inch	150; 5.9
Sound pressure level at maximum permissible air pressure*	dB(A)	82
Sound pressure level at 0.6 MPa; 6 bar; 87 psi air pressure*	dB(A)	80
Sound pressure level at 0.4 MPa; 4 bar; 58 psi air pressure*	dB(A)	75
Material inlet (outside thread)	mm	M36x2
Material outlet (outside thread)	mm	M24x1.5
Weight	kg; lb	80; 176
Material pH value	pH	3.5 ÷ 9
Maxi. material pressure at pump inlet	MPa; bar; psi	2; 20; 290
Material temperature	°C; °F	+5 ÷ +80; 41 ÷ 176
Ambient temperature	°C; °F	+5 ÷ +60; 41 ÷ 140
Allowable inclination for operation	↘°	± 10

* A rated sound pressure level measured at 1 m distance, L pA1m, according to DIN EN 14462: 2005. Reference measurements have been made by SUVA (Swiss accident insurance institute).

	 WARNING
	<p>Outgoing air containing oil! Risk of poisoning if inhaled.</p> <p>→ Provide compressed air free from oil and water (Quality Standard 5.5.4 according to ISO 8573.1) 5.5.4 = 40 µm / +7 / 5 mg/m³.</p>



5.3.4 MEASUREMENTS AND CONNECTIONS

	Tiger 72-300	Unit
A	1158 45.6	mm inch
B	340 13.4	mm inch
C	562 22.1	mm inch
D	518 20.4	mm inch
E	640 25.2	mm inch
F	244 9.6	mm inch
G	230 9.1	mm inch

	Tiger 72-300	Unit
H	110 4.3	mm inch
I	20x48 0.8x1.9	mm inch
J	M8	mm
K	M36x2	mm
L1	M24x1.5	mm
L2	G3/4"	Zoll / inch
M	G 1"	Zoll / inch
O	135 5.3	mm inch

	Tiger 72-300	Unit
P	238 9.4	mm inch
Q	∅9 ∅0.35	mm inch
R	∅9 ∅0.35	mm inch
S	206 8.1	mm inch
T	32 1.3	mm inch

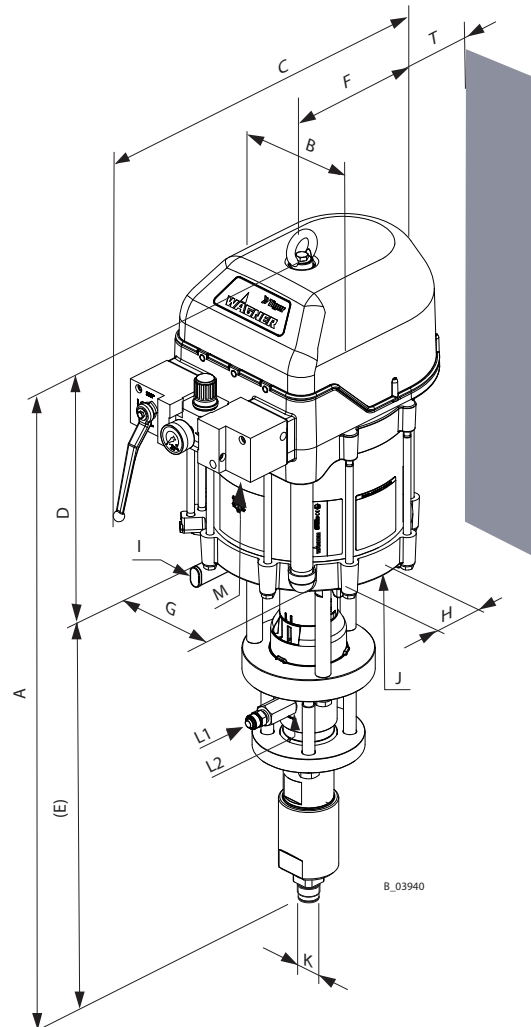
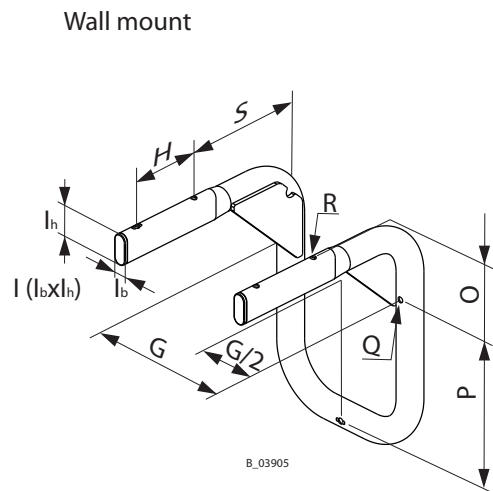

5.3.5 VOLUME FLOW

Wagner AL nozzles			Volume flow* in l/min	
∅ inch	∅ mm	Spray angle	at 10 MPa 100 bar 1450 psi	at 15 MPa 150 bar 2175 psi
0.019	0.48	20-30-40-50-60-70-80°	1.0920	1.3700
0.021	0.53	20-40-50-60-80°	1.3600	1.6900
0.023	0.58	20-40-50-60-70-80°	1.5900	2.0100
0.025	0.64	20-40-50-60-80°	1.9100	2.4000
0.027	0.69	20-40-50-60-80°	2.1300	2.6800
0.029	0.75	60°	2.5100	3.1700
0.031	0.79	20-40-50-60°	2.7700	3.4900
0.035	0.90	20-40-50-60°	3.7400	4.6900
0.043	1.10	20-50°	6.0400	7.4600
0.052	1.30	50°	6.5000	7.5200

* Volume flow refers to water.



5.3.6 PERFORMANCE DIAGRAMS

Example

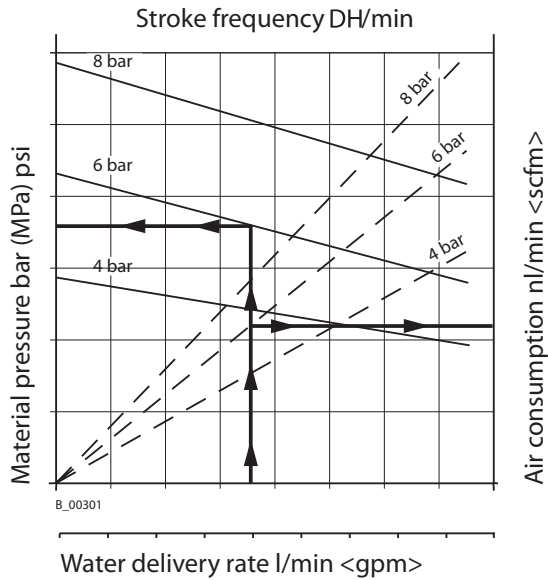
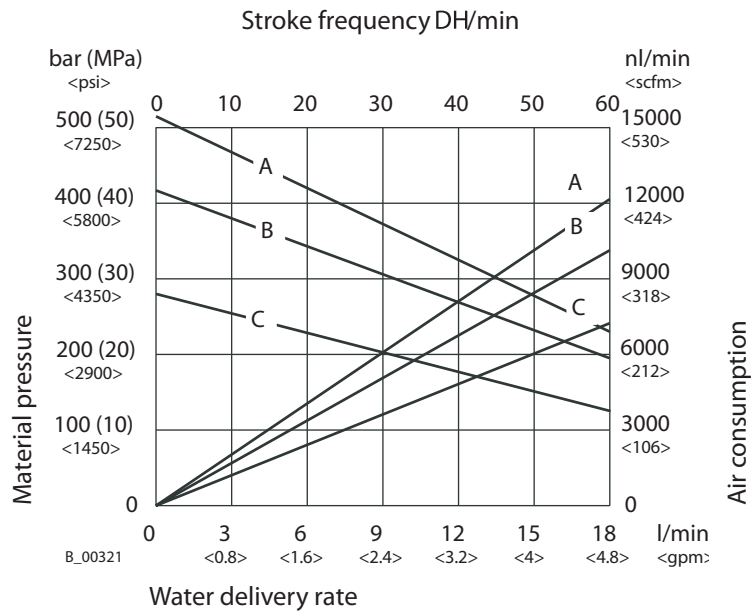

Diagram for TIGER 72-300



- A = 7.4 bar (0.74 MPa/ 107 psi) air pressure
- B = 6 bar (0.6 MPa/ 87 psi) air pressure
- C = 4 bar (0.4 MPa/ 58 psi) air pressure

5.4 FUNCTION

5.4.1 PUMP

- 1 Control housing with integrated silencer
- 2 Air pressure regulator
- 3 Ball valve
- 4 Air motor
- 5 Compressed air inlet
- 6 Mounting flange
- 7 Separating agent cup
- 8 Material outlet
- 9 Fluid section
- 10 Material inlet
- 11 Grounding connection
- 12 Lifting eye nut

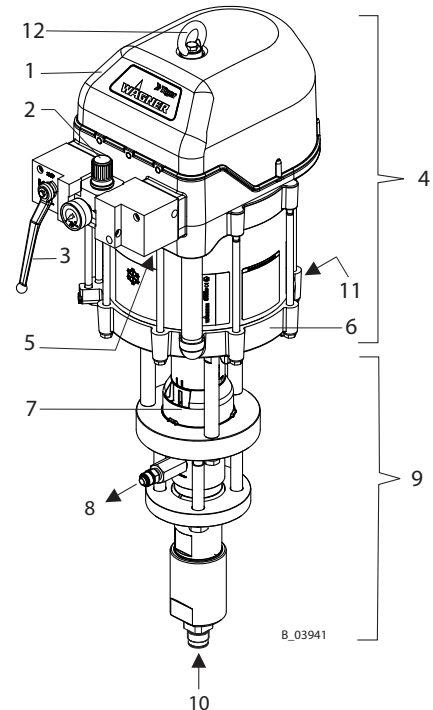

Function principle

The piston pump is driven with compressed air (2). This compressed air moves the air piston up and down in the air motor (4) and it also moves the associated pump piston up and down in the fluid section (9). At the end of each stroke, the compressed air flow is redirected by a reversing valve and the control piston.

The working material is sucked up during the upwards stroke and is continuously conveyed towards the material outlet (8) in both stroke directions.

Air motor (4)

The air motor with its pneumatic reverse (1) does not require pneumatic oil.

The compressed air is fed to the motor over the air regulator (2) and the ball valve (3).

The air motor is fitted with a **safety valve**. The safety valve has been set and sealed at the factory. In case of pressures over and above the permissible operating pressure, the valve, which is held with a spring, automatically opens and releases the excess pressure.

	<p style="margin: 0;">! WARNING</p> <p style="margin: 0;">Overpressure! Risk of injury from bursting components.</p> <p style="margin: 0;">→ Never change the safety valve setting.</p>
---	---

Fluid section (9)

The fluid section has been designed as a piston pump with exchangeable ball valves. The hard chrome-plated pump piston runs in two fixed packings which are self-adjusting by means of a pressure spring, thus resulting in a long service life. Between the air motor and the fluid section there is a separating agent cup (7) for holding the separating agent.

5.4.2 PRESSURE REGULATOR UNIT

- 1 Pressure regulator
- 2 Ball valve
- 3 Pressure gauge
- 4 Compressed air inlet

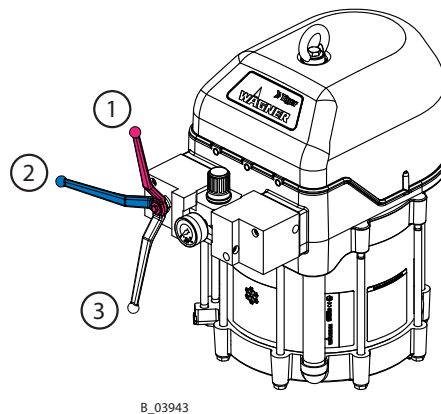
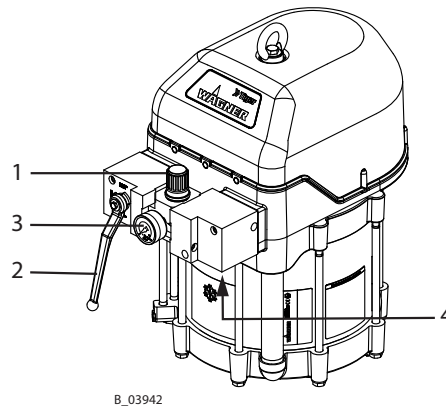

Positions of the ball valve

- 1 Closed: operating pressure in the air motor will be relieved (control pressure is still present).
- 2 Closed: The air motor can still be under pressure.
- 3 Open: working position

5.4.3 HIGH-PRESSURE FILTER (OPTION)

To ensure problem-free operation it is recommended that a WAGNER high pressure filter be used. These have been developed especially for WAGNER pneumatic pumps. The filter inserts can be exchanged depending on the material to be used. The respective high pressure filters and their inserts for the device can be found in the accessories list.

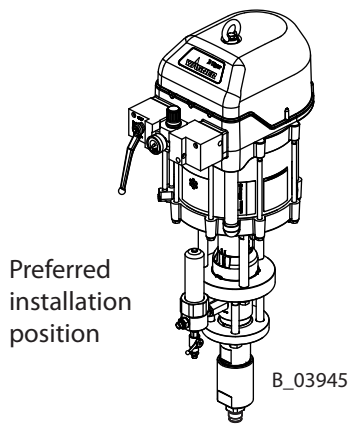

1	Fluid section connection
2	Material outlet
3	Return line

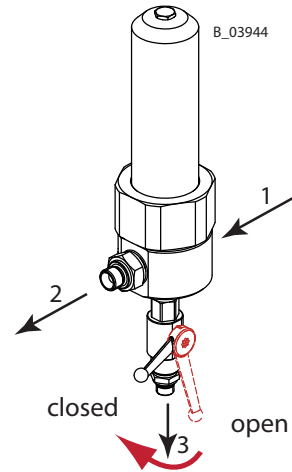

5.4.4 STROKE COUNT (OPTION)

Each air motor has a 1/8" air connection with which the air pressure in the lower air motor chamber can be measured. This signal can be used for counting the strokes in an external control, for example. The pressure signal corresponds to the set working air pressure and is available during the complete upwards stroke of the pump. If both of the signal flanks are evaluated, the upper and lower reversal point can be determined. A 4/2mm; 0.16/0.08 inch air hose is used as an air signal line.

Pos	Order No.	Designation
1	9998675	Threaded plug
2	9999066	Male stud elbow

Pos	Order No.	Designation
3	9982072	Air hose (by length)
4	9943049	Pneumatic pre-selection counter

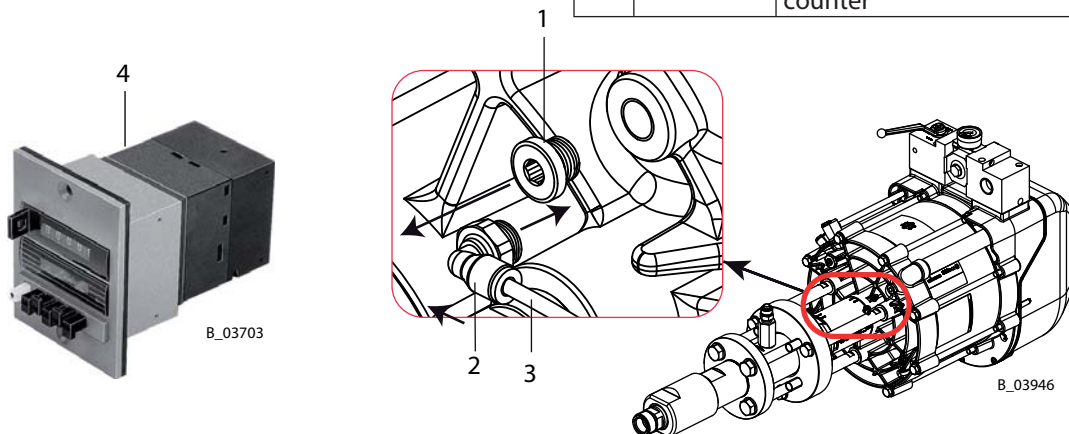

6 ASSEMBLY AND COMMISSIONING

6.1 TRANSPORTATION

The pump must be moved on a trolley (heavy duty trolley) or with lifting equipment or a crane.

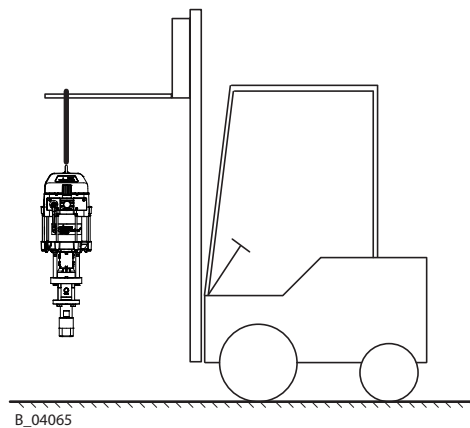

Only pumps without trolleys may be lifted by the ring nut or ring bolt and transported short distances (see accessories).



B_04065

6.2 STORAGE

Store the pump in a closed and dry environment.
Thoroughly clean the pump, if a long-term decommissioning is planned.
When resuming pump operation, proceed as described in the following chapters.

	 WARNING
	<p>Discharge of electrostatically charged components in atmospheres containing solvents! Explosion hazard from electrostatic sparks.</p> <p>→ Clean the pump only with a damp cloth.</p>

6.3 ASSEMBLING THE PUMP

Note

This pump can be used as part of a spraying system for Airless spraying. The individual components are shown in the Wagner accessories, or can be arranged with a spraypack configurator. The nozzles must be selected according to the gun instructions.

Procedure:

- a) Mount pump on wall mount (6) or trolley.
- b) Mount high pressure filter (3).
- c) Mount suction system (5).
- d) Mount return tube (4) or return hose.
- e) Connect high pressure hose and gun as laid down in the operating manual for gun (2).

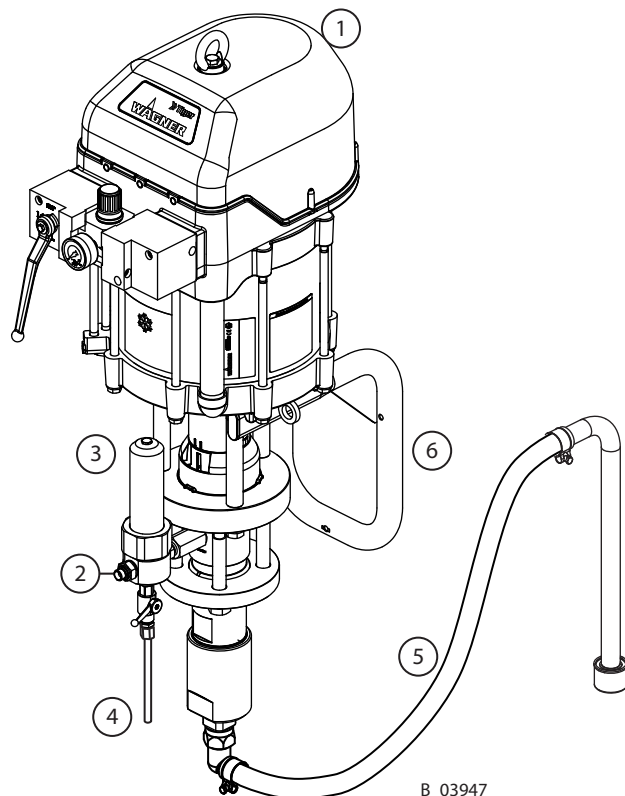

B_03947

**! WARNING****Inclined ground!**

Risk of accidents if the device rolls away/falls.

- Position the carriage with the piston pump horizontally.
- If the surface is inclined, position the feet of the trolley towards the gradient.
- Secure the trolley.

6.4 GROUNDING

	WARNING
	<p>Discharge of electrostatically charged components in atmospheres containing solvents! Explosion hazard from electrostatic sparks.</p> <ul style="list-style-type: none"> → Clean the piston pump only with a damp cloth. → Ground all device components. → Ground the workpieces to be coated.

	WARNING
	<p>Heavy paint mist if grounding is insufficient! Danger of poisoning. Insufficient paint application quality.</p> <ul style="list-style-type: none"> → Ground all device components. → Ground the work pieces to be coated.

Grounding scheme (example)

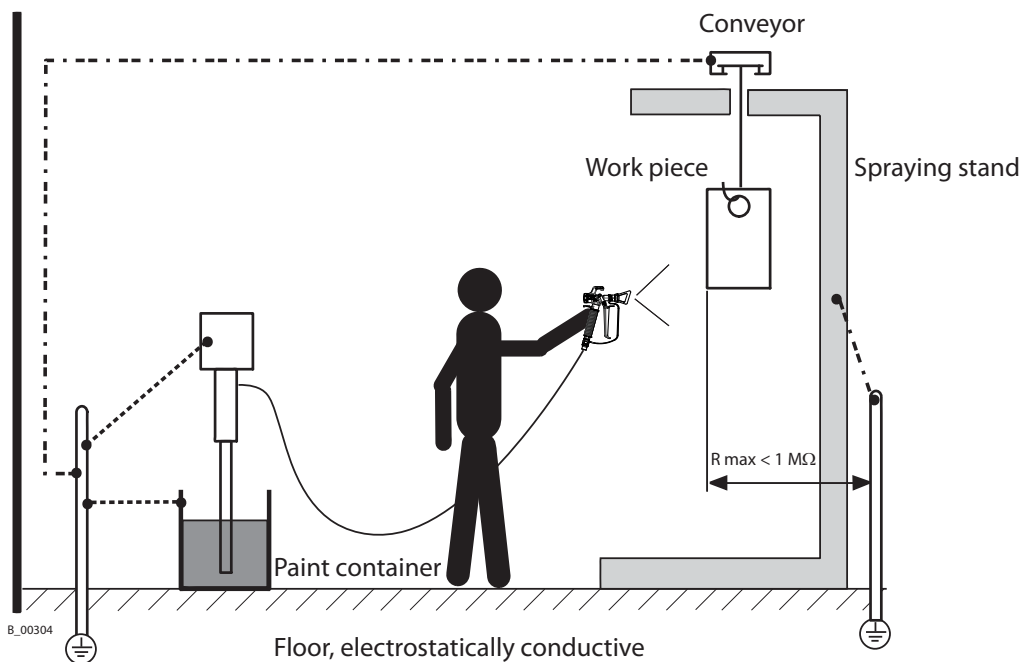

B_00304

The grounding connection is mandatory with the IceBreaker Pumps.

Cable cross sections

Pump	4 mm ² ; AWG11
Paint container	6 mm ² ; AWG10
Conveyor	16 mm ² ; AWG5
Booth	16 mm ² ; AWG5
Spraying stand	16mm ² ; AWG5

Procedure:

1. Screw on grounding cable with eye.
2. Clamp the grounding cable clip to a grounding connection on site.
3. Ground the material (paint) container to an on-site grounding connection.
4. Ground the other parts of the system to an on-site grounding connection.
16 mm²; AWG5

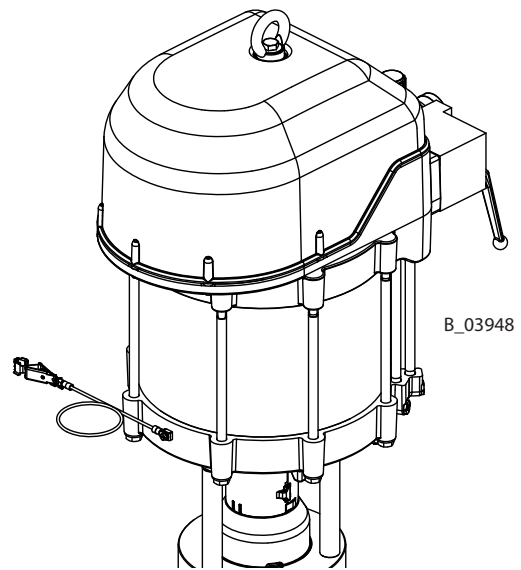





6.5 COMMISSIONING

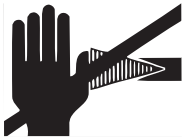

6.5.1 SAFETY INSTRUCTIONS

Every time before starting up, the following points should be observed as laid down in the operating manual:

- Observe all safety regulations in accordance with Chapter 4.
- Carry out commissioning properly.

	 WARNING
	<p>High pressure spray jet! Danger to life from injecting paint or solvent.</p> <ul style="list-style-type: none"> → Never reach into the spray jet. → Never point the spray gun at people. → Consult a doctor immediately in the event of skin injuries caused by paint or solvent. Inform the doctor about the paint or solvent used. → Never seal defective high pressure parts, instead relieve the pressure from them and replace them.

	 WARNING
	<p>Toxic and/or flammable vapor mixtures! Risk of poisoning and burns.</p> <ul style="list-style-type: none"> → Operate the device in a spray booth approved for the working materials. - or - → Operate the device on an appropriate spraying wall with the ventilation (extraction) switched on. → Observe national and local regulations for the outgoing air speed.

	 WARNING
	<p>Gas mixtures can explode if there is an incompletely filled pump! Danger to life from flying parts.</p> <ul style="list-style-type: none"> → Ensure that the pump and suction system are always completely filled with flushing agent or working medium. → Do not spray the device empty after cleaning.

Before every start-up, the following points should be observed as laid down in the operating manual:

- Secure gun with safety clip.
- Check the permissible pressures.
- Check all connections for leaks.
- Check hoses for damage.

It should be ensured that the device is in the following state before carrying out any work on it:

- The pressure should be released from the pump and high-pressure hose with gun.
- The gun should be secured with the safety clip.
- Interrupt the air supply.

EMERGENCY STOP

In case of unforeseen occurrences the ball valve (2) should be closed immediately and the return valve (3) opened.

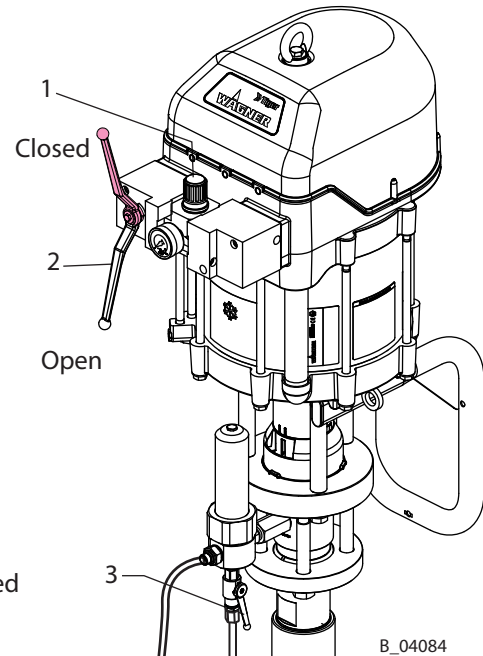

B_04084

6.5.2 FILLING WITH SEPARATING FLUID

NOTICE

Piston pump dry run!

High wear/damage to the packages.
Paint or solvent can escape if the seals are dry.

- Ensure that the separating agent container is filled with sufficient separating agent.
Fill level 1 cm; 0.4 inch under the pot edge.

Place the supplied separating agent into the separating agent cup.

Filling level: 1 cm; 0.4 inch under the cup edge

Separating agent: Order No. 9992504

Notice

Maximum permissible inclination of pump for moving, transportation etc. after filling it with separating agent: $\pm 30^\circ$.

The pump must be vertical during operation.

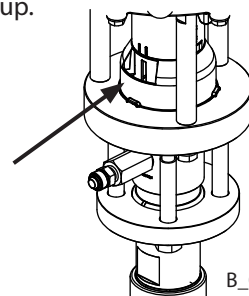

B_04085

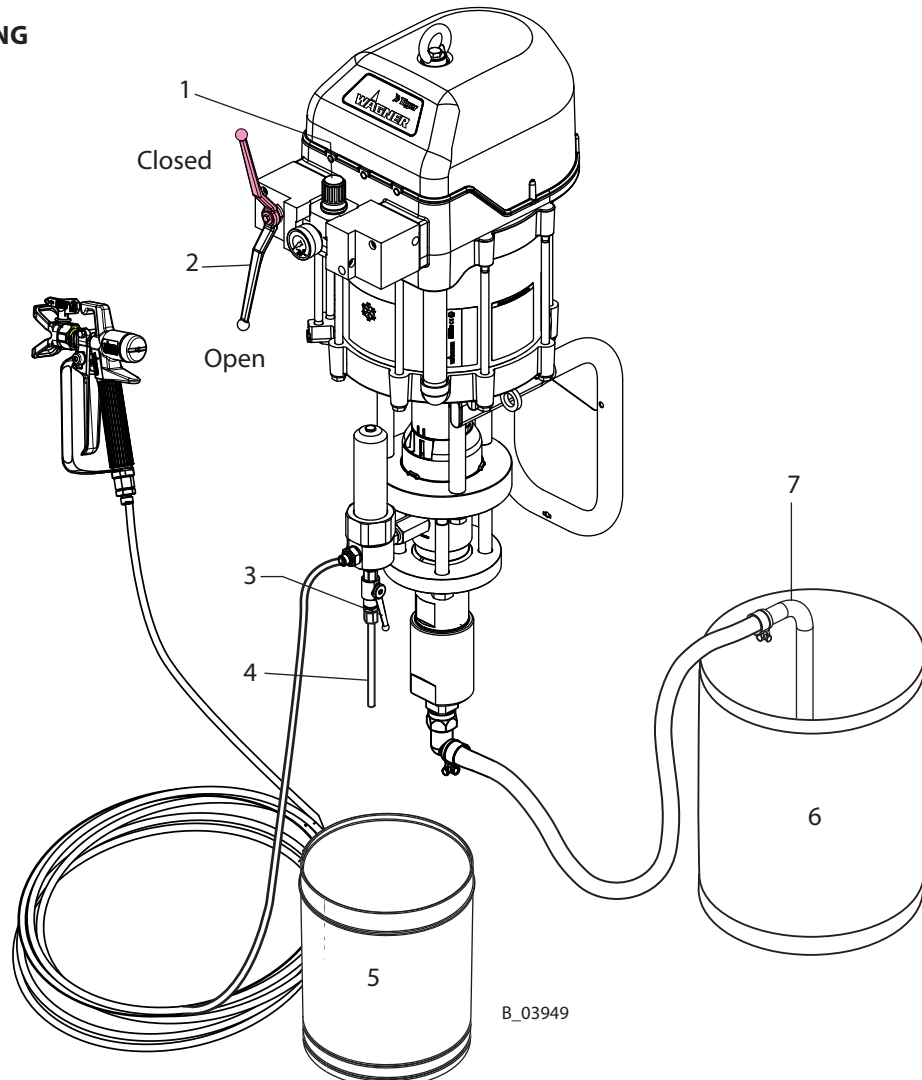
6.5.3 BASIC FLUSHING

1. Place empty container (5) under return tube (4).
2. Place suction hose (7) in the container with flushing agent (6).
3. Adjust the pressure regulator (1) to approx. 0.05 MPa; 0.5 bar; 7.25 psi.
4. Open return valve (3).
5. Slowly open the ball valve (2).
6. Adjust the air pressure on the pressure regulator (1) so that the pump runs smoothly.
7. Rinse the system until clean flushing agent flows into the container (5).
8. Close ball valve (2).
9. Close return valve (3)
10. Point the gun, without nozzle, into container (5) and open it.
11. Slowly open the ball valve (2).
12. Rinse until clean flushing agent flows from the gun.
13. Close ball valve (2).
14. When there is no pressure remaining in the system, close the gun.
15. Secure the gun.
16. Dispose of the contents of the container (5) according to the local regulations.

7 OPERATION

7.1 FILLING WITH WORKING MATERIAL

1. Place empty container (5) under return tube (4).
2. Place suction hose (7) in the container with working material (6).
Note:
If the pump is equipped with a rigid suction system, it should only be dipped in into the working material up to the middle of the inlet housing at the maximum!
3. Adjust the pressure regulator (1) to approx. 0.05 MPa; 0.5 bar; 7.25 psi.
4. Open return valve (3).
5. Slowly open the ball valve (2).
6. Adjust the air pressure on the pressure regulator (1) so that the pump runs smoothly.
7. Close ball valve (2) as soon as pure working material starts coming from the return tube (4).
8. Close return valve (3).
9. Point the gun, without nozzle, into container (5) and open it.
10. Slowly open the ball valve (2).
11. Close ball valve (2) as soon as pure working material starts coming from the gun.
12. When there is no pressure remaining in the system, close the gun.
13. Secure the gun.
14. Dispose of the contents of the container (5) according to the local regulations.

7.2 WORK

7.2.1 SPRAYING

1. Secure gun and place nozzle in the gun.
2. Slowly open the ball valve (2).
3. Set required working pressure on the pressure regulator (1).
4. Optimize the spraying results as laid down in the gun instructions.
5. Start work process.

7.2.2 PRESSURE RELIEF / WORK INTERRUPTION

1. Close gun.
2. Close ball valve (2).
3. Release the system by opening the gun.
4. Close and secure gun.
5. Open and close the return valve (3) to completely depressurize the system.

If the system has been used with two component materials:

NOTICE

Hardened material in the spraying system when 2-component material is processed!

Destruction of pump and injection system.

- Follow the manufacturer's processing rules, particularly regarding the pot life.
- Flush thoroughly before the end of the pot life.
- The pot life is decreased by warmth.



7.2.3 DECOMMISSIONING AND CLEANING

Note



The device should be cleaned for maintenance purposes. Ensure that no remaining material dries and sticks.

Procedure:

1. Work interruptions -> carry out the steps in Chapter 7.2.2.
2. Carry out the basic flushing -> Chapter 6.5.3.
3. Maintain the gun according to the operating manual.
4. Clean and check the suction system and the suction filter.
5. When using a high pressure filter:
Clean and check the filter insert and filter body.
6. Clean the outside of the system.

	 WARNING
	<p>Brittle filter pressure regulator! The container on the filter pressure regulator becomes brittle through contact with solvents and can burst. Flying parts can cause injury.</p> <p>→ Do not clean the container on the filter pressure regulator with solvents.</p>

7. Put the whole system back together.
8. Check the level of the separating agent -> Chapter 6.5.2.
9. Fill the system with flushing agent as laid down in Chapter 7.1 "Filling with Working Material".

	 WARNING
	<p>Gas mixtures can explode if there is an incompletely filled pump! Danger to life from flying parts.</p> <p>→ Ensure that the pump and suction system are always completely filled with flushing agent or working medium. → Do not spray the device empty after cleaning.</p>

7.3 LONG-TERM STORAGE

When storing the device for longer periods of time, it is necessary to thoroughly clean it and protect it from corrosion. Replace the water or solvent in the material pump with a suitable preservative, fill separating agent cup with separating agent.

Procedure:

1. Carry out points 1 through 9 in Chapter 7.2.3 "Decommissioning and Cleaning".
2. Flushing with preservative according to Chapter 6.5.3.



8 TROUBLE SHOOTING AND RECTIFICATION

8.1 TROUBLE SHOOTING AND RECTIFICATION

Problem	Cause	Remedy
Pump does not work.	Air motor does not work or stops.	Open and close ball valve on the pressure regulator unit or briefly disconnect compressed air supply.
	No pressure indication on the pressure gauge (pressure regulator defective).	Disconnect compressed air supply briefly or repair or replace pressure regulator.
	Spray nozzle is clogged.	Clean the nozzle according to the instructions.
	Insufficient compressed air supply.	Check compressed air supply.
	Filter insert in spray gun or high pressure filter is clogged.	Clean the parts and use a suitable working material.
	Fluid section or high pressure hose are blocked (e.g., two-component material hardened).	Dismount and clean fluid section, replace high pressure hose.
	Grease in spool and sleeve assembly.	Degrease spool and sleeve assembly.
	Pump stops at the stroke end.	Check detent element (see service manual).
Poor spray pattern	See gun instructions.	
Irregular operation of material pump: spray jet collapses (pulsation).	Viscosity is too high.	Thin spraying material.
	Spraying pressure is too low.	Increase incoming air pressure. Use a smaller nozzle.
	Valves are clogged.	Clean material pump, if necessary leave it to soak in cleaning agent.
	Foreign body in suction valve	Dismount suction valve housing, clean and check valve seat.
	Diameter of compressed air line too small.	Assemble a larger incoming line -> Technical Data, Chapter 5.3.3.
	Valves, packings or pistons are worn out.	Replace the parts.
	Control air filter or work air filter is clogged.	Check filter and clean it if necessary.
The pump runs evenly, does not however, suck up material.	The suction system's union nut is loose; the pump is taking in air.	Tighten union nut.
	Suction filter is clogged.	Clean filter.
	Ball in suction or piston valve is stuck.	Clean with flushing agent (if necessary vent device).
Pump runs when the gun is closed.	Packings, valves or pistons are worn out.	Replace the parts.
Air motor is iced up.	There is a lot of condensation water in the air supply.	Install a water separator.

If none of the causes of malfunction mentioned are present, the defect can be remedied by a WAGNER Service Center.

9 MAINTENANCE

	 WARNING
	<p>Incorrect maintenance/repair! Danger to life and equipment damage.</p> <ul style="list-style-type: none"> → Only a WAGNER service center or a suitably trained person may carry out repairs and replace parts. → Only repair and replace parts that are listed in the "Spare Parts" chapter and that are assigned to the device. → Before all work on the device and in the event of work interruptions: <ul style="list-style-type: none"> - Disconnect the control unit from the mains. - Relieve the pressure from the spray gun and device. - Secure the spray gun against actuation. → Always follow the operating and service instructions at all times when carrying out work.



1. Check the level of separating agent in the separating agent cup every day, and top up if necessary.
 2. Check and clean the high pressure filter every day or as required.
 3. Every shut down should be carried out as laid down in Chapter 7.2.3!
 4. Check hoses, pipes and couplings every day and replace if necessary.
- In accordance with the guideline for liquid ejection devices (ZH 1/406 and BGR 500 Part 2 Chapter 2.36):
- The liquid ejection devices should be checked by an expert (e.g. Wagner service technician) for their safe working conditions as required and at least every 12 months.
 - For shut down devices, the examination can be suspended until the next start-up.

The service instructions are available in German and English.
Order number see Chapter 1.

9.1 HIGH-PRESSURE HOSES

The service life of the fluid hoses is, even with appropriate handling, reduced due to environmental influences.

- Check hoses, pipes and couplings every day and replace if necessary.
- As a precaution fluid hoses should be replaced after a period specified by the plant operator.

	 DANGER
	<p>Bursting hose, bursting threaded joints! Danger to life from injection of material.</p> <ul style="list-style-type: none">→ Ensure that the hose material is chemically resistant to the sprayed materials.→ Ensure that the spray gun, threaded joints and material hose between the device and the spray gun are suitable for the pressure generated in the device.→ Ensure that the following information can be seen on the high pressure hose:<ul style="list-style-type: none">- Manufacturer- Permissible operating pressure- Date of manufacture

9.2 DECOMMISSIONING

When the equipment must be scrapped, please differentiate the disposal of the waste materials.

The following materials have been used:

- Steel
- Aluminum
- Elastomerics
- Plastics
- Carbide

The consumable materials (paints, adhesives, sealers, solvents) must be disposed of according to the valid specific standards.

10 ACCESSORIES

10.1 MATERIAL OUTLET ACCESSORIES

List accessories

Pos	K	Order No.	Designation
A		2329511	Tiger piston pump 72-300 PE/L
A		2329513	Tiger piston pump 72-300 PE/T
A		2329515	Tiger piston pump 72-300 PE/TG
1		9992504	Separating agent 250 ml; 250 cc
2		356940	Separating agent 10 L; 2.6 gal.
3		236219	Ground cable 3 m; 9.8 ft
4		2329025	HP filter DN12 PN530-SSt with stainless steel ball valve
5		2335334	HP filter DN12 PN530-SSt with carbon steel ball valve
6	◆	2331752	Return tube DN6-G1/4"-100mm-PA
7	◆	2329046	Return hose DN6-PN310-G1/4"-PA
8	◆	2331017	Circulation hose DN6-PN310-G1/4"-1.8m-PA
9	◆	2331014	Circulation hose DN6-PN310-G1/4"-2.8m-PA
10		9985671	Outside thread grommet 1"-NW25
11		9974135	Sealing ring 1"
12		2332620	Adapter G3/8"-NPS 3/8"
13		2334958	Regulator lock

◆ = Wearing parts

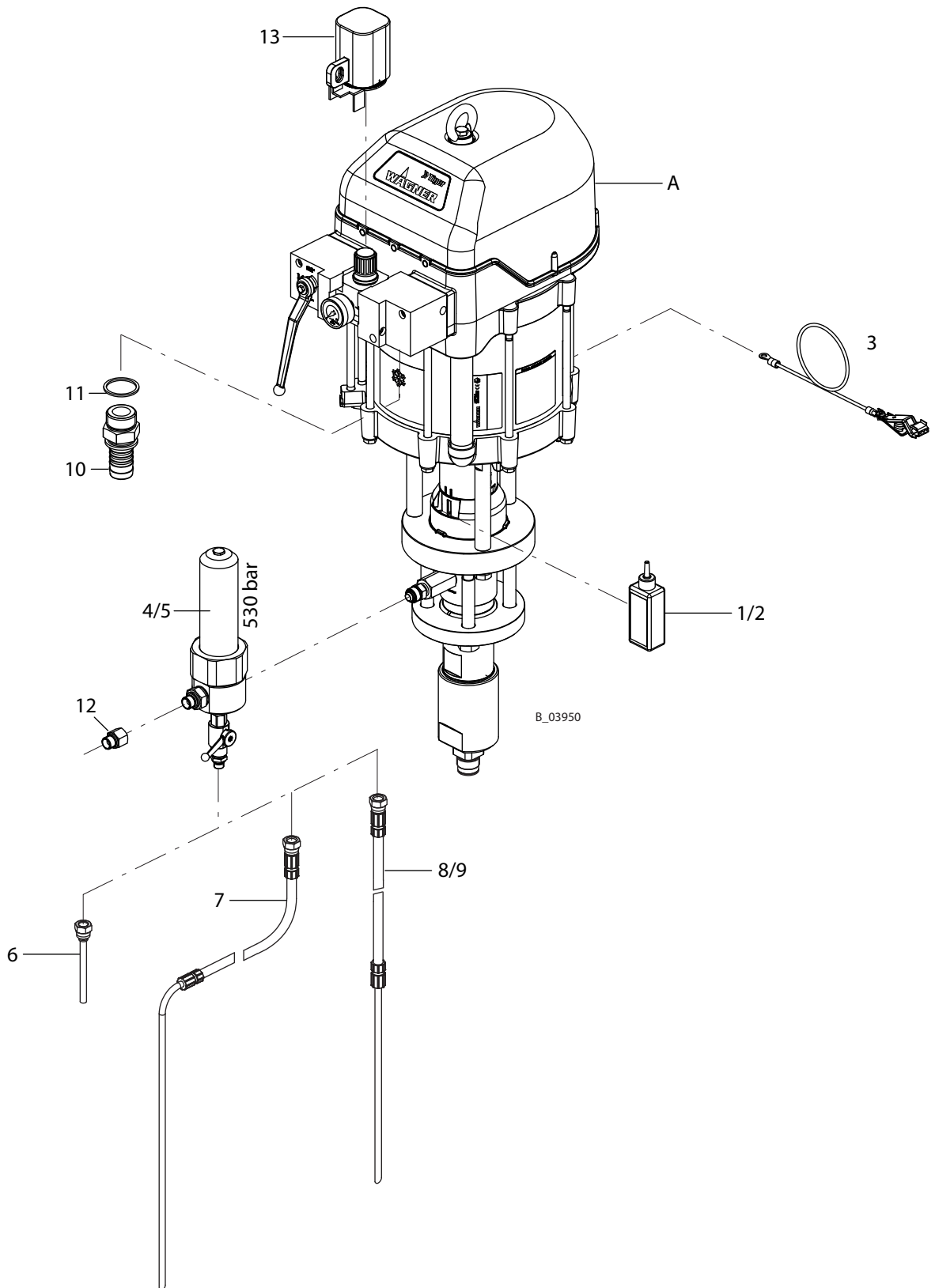

10.2 MATERIAL INLET ACCESSORIES

For trouble-free intake, use hoses which are as short as possible. The maximum hose length is dependent upon the viscosity of the material, the suction height and the nominal diameter of the hose.

List accessories

Pos	K	Order No.	Designation
A		2329511	Tiger piston pump 72-300 PE/L
A		2329513	Tiger piston pump 72-300 PE/ T
A		2329515	Tiger piston pump 72-300 PE/ TG
1	◆	2324116	Suction hose DN25-SSt, complete
2	◆	2329592	Suction hose DN38-SSt, complete
3		2325408	LP hose fitting DN25-M36-SSt
4	◆	2323474	LP hose DN25-PN10-EPDM (per meter)
5	◆	2323595	LP hose DN25-PN10-PE (per meter)
6		2323239	Suction pipe DN25-SSt, complete
7		2324247	Suction elbow DN25-SSt
8		2324238	Suction pipe DN25-200L-SSt, complete
9		2315163	Bung adapter DN25-G2"
10		2324241	Suction pipe DN25-30L-SSt, complete
11	◆	2323325	Suction filter DN25-18mesh-SSt
12	◆	2329596	Suction filter DN38-12.8mesh-SSt
13		2329073	Fitting DF-MM-R1½"-G1½"-PN15-SSt
14		9992609	Anti-sieze paste

◆ = Wearing parts

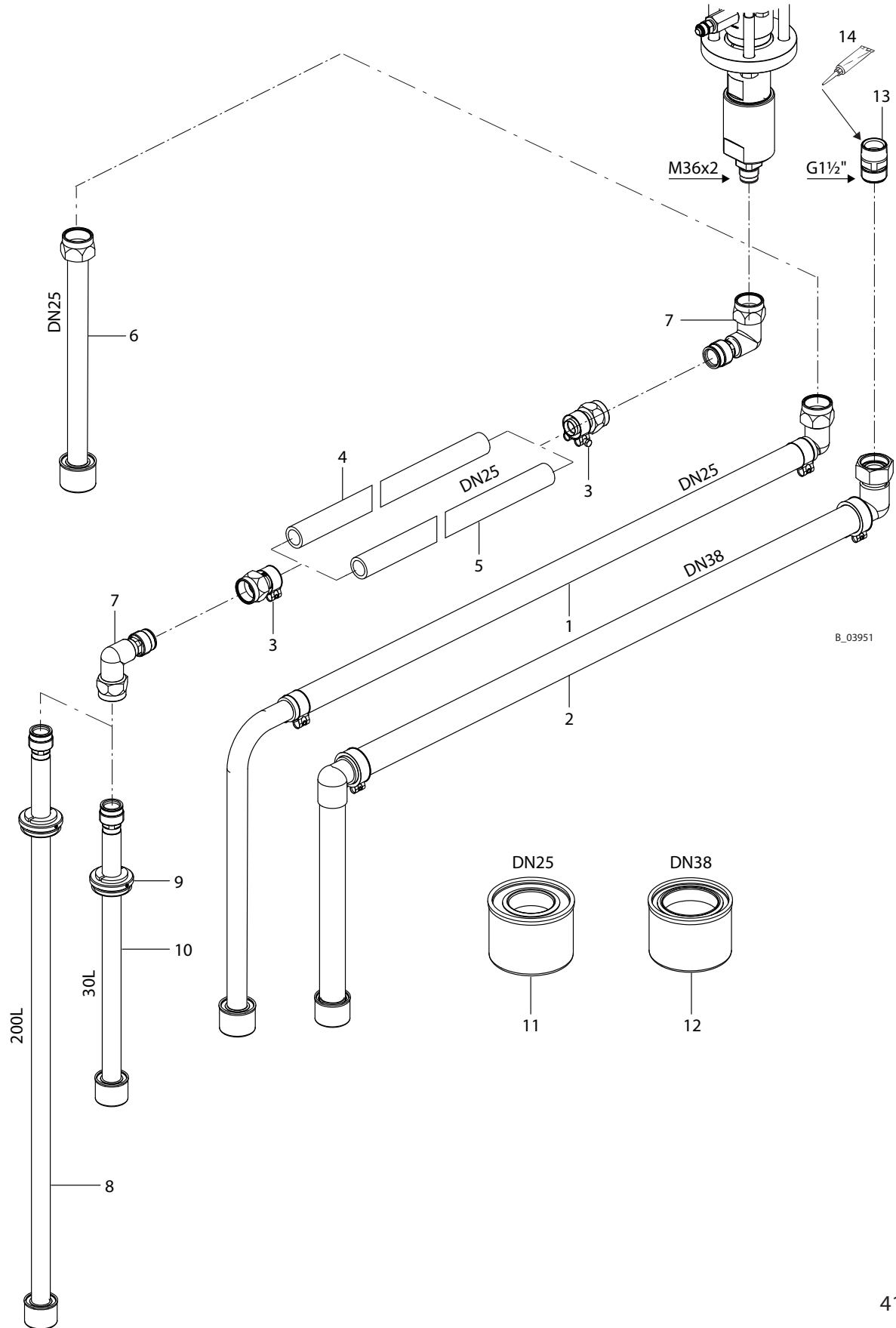

10.3 TROLLEY AND WALL BRACKET ACCESSORIES

List accessories

Pos	K	Order No.	Designation
A		2329511	Tiger piston pump 72-300 PE/L
A		2329513	Tiger piston pump 72-300 PE/T
A		2329515	Tiger piston pump 72-300 PE/TG
1		369020	Wall bracket 9", complete
2		369024	Trolley Heavy Duty, complete

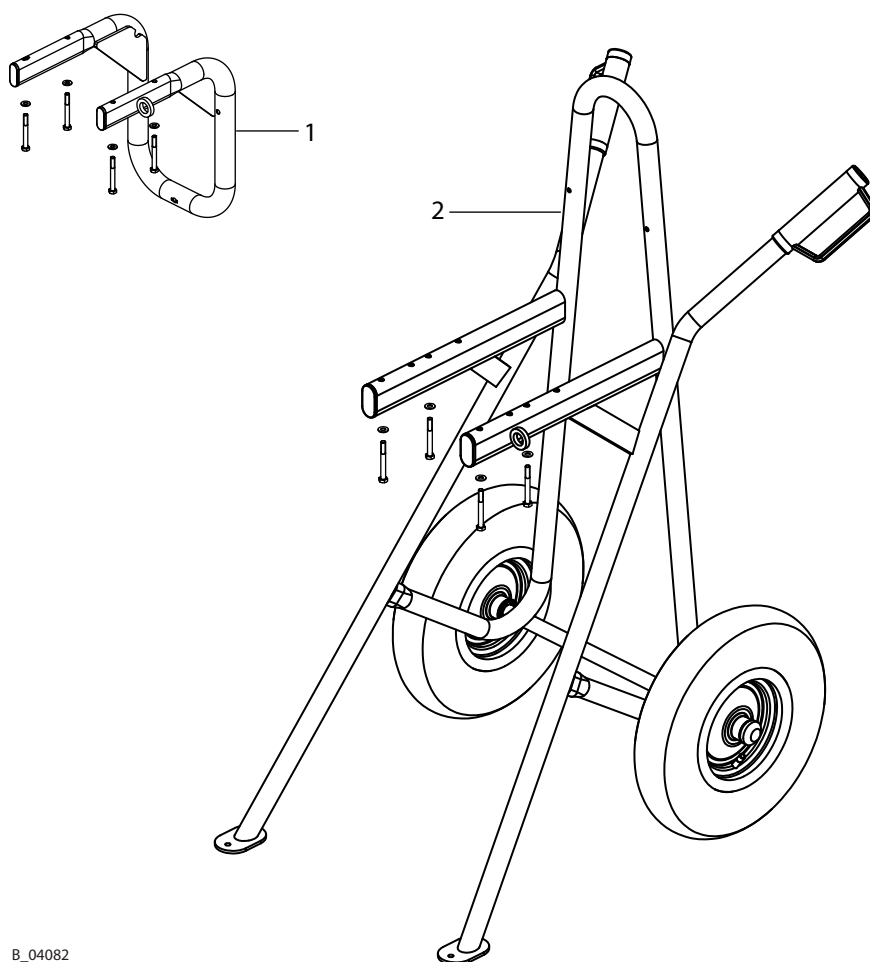

B_04082

11 SPARE PARTS

11.1 HOW CAN SPARE PARTS BE ORDERED?

Always supply the following information to ensure delivery of the right spare part:

Order number, designation and quantity

The quantity need not be the same as the number given in the quantity column "Stk" on the list. This number merely indicates how many of the respective parts are used in each module.

The following information is also required to ensure smooth processing of your order:

- Billing address
- Delivery address
- Name of the person to be contacted in the event of any queries
- Type of delivery (normal mail, express delivery, air freight, courier etc.)



Identification in spare parts lists

Explanation of column "K" (labeling) in the following spare parts lists:

- ◆ Wearing parts

Note: No liability is assumed for wearing parts.

- Not part of standard equipment, available, however, as special accessory.



	 WARNING
	<p>Incorrect maintenance/repair! Risk of injury and equipment damage.</p> <p>→ Have repairs and part replacements be carried out only by specially trained staff or a WAGNER service center.</p> <p>→ Before all work on the device and in the event of work interruptions:</p> <ul style="list-style-type: none"> - Switch off the energy/compressed air supply. - Relieve the pressure from the spray gun and device. - Secure the spray gun against actuation. <p>→ Always follow the operating and service instructions at all times when carrying out work.</p>

11.2 OVERVIEW OF COMPONENTS

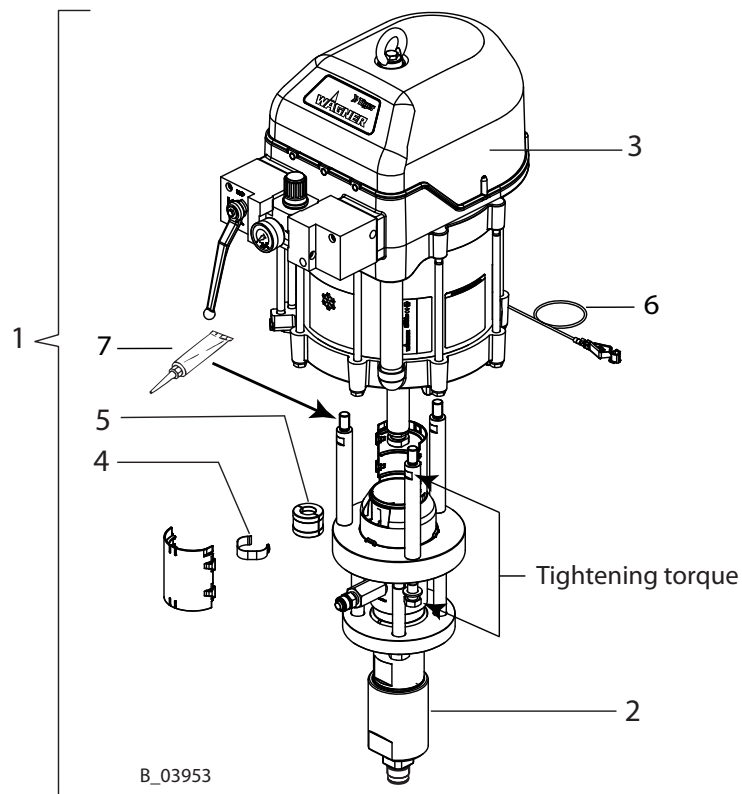
		Tiger 72-300 PE/L	Tiger 72-300 PE/TG	Tiger 72-300 PE/T
Pos	Designation	Order No.	Order No.	Order No.
1	Piston pump	2329511	2329515	2329513
2	Fluid section	2329666	2329671	2329669
3	Air motor	2329627		
4	Spring	370530		
5	Coupling	370529		
6	Grounding cable, complete	236219		
7	Molykote DX grease	9992616		
Tightening torque air motor / fluid section		70 Nm; 52 lbft		



11.3 AIR MOTOR**11.3.1 TIGER AIR MOTOR**

	 WARNING
	<p>Incorrect maintenance/repair! Risk of injury and equipment damage.</p> <p>→ Have repairs and part replacements be carried out only by specially trained staff or a WAGNER service center.</p> <p>→ Before all work on the device and in the event of work interruptions:</p> <ul style="list-style-type: none"> - Switch off the energy/compressed air supply. - Relieve the pressure from the spray gun and device. - Secure the spray gun against actuation. <p>→ Always follow the operating and service instructions at all times when carrying out work.</p>

Tiger air motor spare parts list

Pos	K	Designation	Stk	Order No.
1		Air motor, complete	1	2329627
2		Shoulder ring	1	369324
3		Lifting eye nut	1	369325
4	◆	Pressure regulator unit 12 (incl. Pos. 40)	1	2328610
5		Control air pipe 150	2	367405
6		Pistonwasher 12	1	370303
7		Damping washer 12	2	370304
8		Piston 12	1	370385
9	◆	Piston rod 12/150	1	370402
10		Hexagon nut	1	9913051
11	◆ ★	O-ring	1	9974261
13		Base	1	9952668
14		Clamping bracket	1	9952667
15		Spring washer	1	9921505
16		Socket screw with slit	1	9900701
17		Gauging pin	1	370307
18		Valve cover	2	370309
19		Spiral spring	2	370310
20		Screw plug	2	370311
21	◆	Valve body	2	370312
22		Lock washer	2	9922724
23	◆	O-ring	2	9974102
24		Flange 12	1	370316
25	◆	Permaglide bushing	1	9962026

◆ = Wearing part

★ = Included in service set

Tiger air motor spare parts list

Pos	K	Designation	Stk	Order No.
26	◆	O-ring	1	9971446
27	◆ ★	Scraper ring d35	1	9974158
28	◆ ★	Rod seal d35	1	9974159
29		Threaded plug	1	9998675
30		Threaded plug	2	9998274
31		Air tube 12	1	370306
32		Cylinder tube 12/150	1	370403
33	◆ ★	O-ring	1	9971129
35	◆ ★	O-ring	4	9974089
36		Hood 9	1	369311
37	◆	Sound absorbing mat 9	1	369319
38		WAGNER 12 Tiger label	1	2330374
39		Hexagon bolt	1	9900150
41		Hexagon bolt	8	9907208
42		Screw	5	9907125
43		Washer	8	9920107
44		Washer	1	9925034
45		Silencer 9	1	369310
46		Shoulder screw 9	1	369318
47	◆ ★	Control air filter	1	367314
48		Filter holder	1	367324
49		Throttle	1	367325
50		Connecting part 9	1	369309
51	◆ ★	Filter compressed air 9	1	369313
52	◆ ★	Discharger Gasket DE 50	2	369312
53		Stop plate 12	1	370313
54		Sealing plug 12	1	370314
55		Control housing 12	1	370315
56		Securing ring	2	370330
57	◆	Spool and sleeve assembly	1	9943121
58	◆	O-ring	6	9974160
59		Safety valve 0.78 MPa; 7.8 bar; 113 psi	1	2302480
60	◆ ★	Sealing ring	1	9970149
61	◆ ★	O-ring	2	9974092
62		Screwing in angle 8-1/4"	2	9998253
63		Screwing in angle 8-1/8"	2	9992757
64		Air hose front	1	370233
65		Air hose back	1	370234
66		Air hose down	2	370235
67		Gauging pin	1	370308
68		Control-flange 12	1	370317

◆ = Wearing part

★ = Included in service set

Tiger air motor spare parts list

Pos	K	Designation	Stk	Order No.
69		Compressed air tube 12	1	370404
70		Socket screw	4	9900313
71		Socket screw	3	9900314
72		Washer	4	9920102
73		Washer	3	9925029
74	◆	O-ring	5	9971004
75	◆ ★	O-ring	1	9971129
76	◆	O-ring	1	9971372
77	◆ ★	O-ring	2	9974132
78		Screwing in angle 8-1/8"	1	9992757
79		Threaded connector L	1	9998613
80		IceBreaker label	1	2330382
81		Pin for control flange	2	370318
82		Threaded fitting, straight	1	9992744
83		Threaded fitting, straight	1	9992743
84		Screw SFS Plastite 45	2	9907125
85		Washer	2	9925031
86	◆	O-ring	1	9974165
90		Elbow ball valve housing 12	1	370323
107		Warning label	1	2332077
108	◆	Velcro fastener adhesive part	1	9999151
109	◆	Velcro fastener coating part	1	9999152
111		"Miranit" adhesive	1	9992816
112		Loctite 222 50 ml; 50 cc	1	9992590
113		Loctite 243 50 ml; 50 cc	1	9992511
114		Loctite 542 50 ml; 50 cc	1	9992831
115		Molykote DX grease	1	9992616
116		Grease Beacon	1	9998808
118		Fluid warning label	1	2332082
		Service set, air motor 12	1	370987

◆ = Wearing part

★ = Included in service set

11.3.2 TIGER AIR MOTOR REGULATOR

Tiger air motor regulator spare parts list



Pos	K	Designation	Stk	Order No.																														
1		Pressure regulator unit 12", complete	1	2328610																														
2	◆	Pressure regulator valve 12"	1	2309974																														
3		Distibutor block LR-D Maxi 12	1	2310588																														
4	◆	Pressure gauge 0-10 bar (d50)	1	9998725																														
5		Hexagon socket head screw	4	9900360																														
6		Hexagon socket head screw	2	9907087	7	◆	O-ring	1	9974166	8		O-ring	2	3105540	9	◆	O-ring	1	9971405	10	◆	Elbow ball valve LR-D Maxi 12	1	2310638	11		Molykote DX grease	1	9992616	12		Grease Beacon	1	9998808
7	◆	O-ring	1	9974166																														
8		O-ring	2	3105540																														
9	◆	O-ring	1	9971405																														
10	◆	Elbow ball valve LR-D Maxi 12	1	2310638																														
11		Molykote DX grease	1	9992616																														
12		Grease Beacon	1	9998808																														

◆ = Wearing part

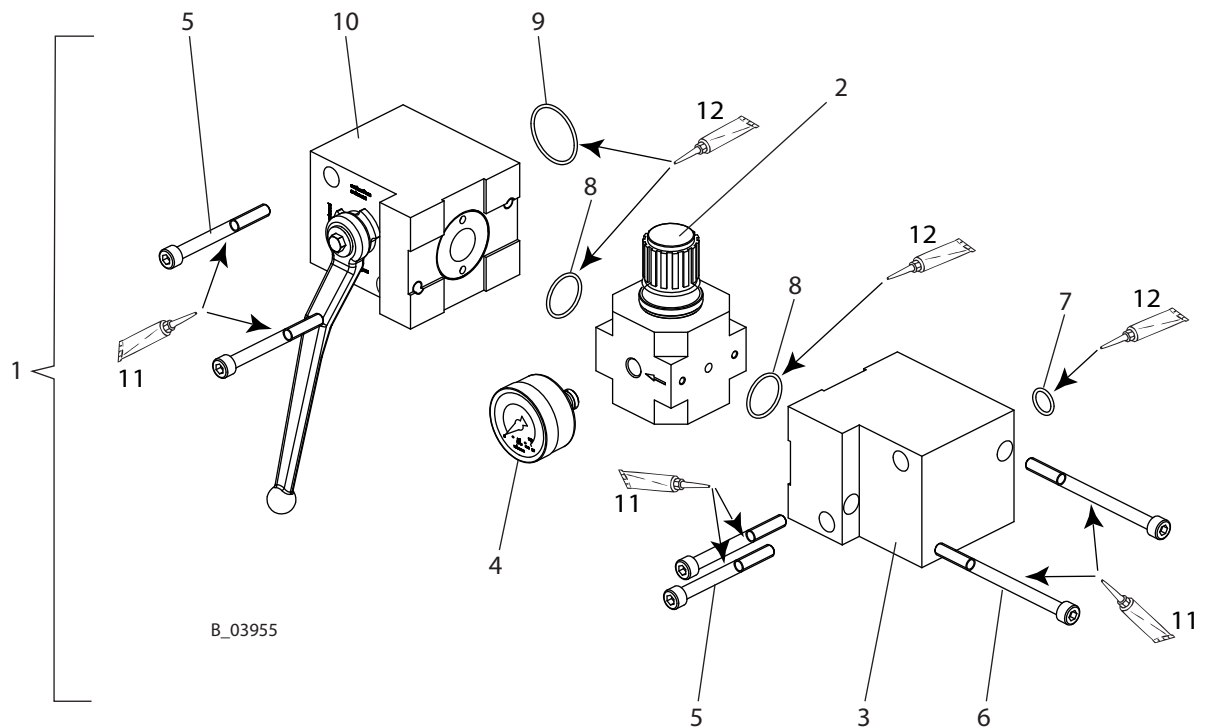
★ = Included in service set



11.4 FLUID SECTION 300 CM³

	 WARNING
	<p>Incorrect maintenance/repair! Risk of injury and equipment damage.</p> <p>→ Have repairs and part replacements be carried out only by specially trained staff or a WAGNER service center.</p> <p>→ Before all work on the device and in the event of work interruptions:</p> <ul style="list-style-type: none"> - Switch off the energy/compressed air supply. - Relieve the pressure from the spray gun and device. - Secure the spray gun against actuation. <p>→ Always follow the operating and service instructions at all times when carrying out work.</p>

Fluid sections spare parts list

Pos	K	Stk	Designation	300 cm ³ PE/TG	300 cm ³ PE/L	300 cm ³ PE/T
				Order No.	Order No.	Order No.
1		1	Fluid section 300 cm ³	2329671	2329666	2329669
2		2	Coupling cover stroke 150		368532	
3		1	Support ring 35.8/52-300		369516	
4	◆ ★	3	Sealing collar PE 35.8/ 52		368523	
5	◆ ★	2	Sealing collar L 35.8/ 52		368922	
5	◆ ★	2	Sealing collar TG 35.8/ 52	368522		
5	◆ ★	2	Sealing collar T 35.8/ 52			368900
6		1	Pressure ring 35.8/52		368519	
7	◆ ★	1	Spirawave, crest-to-crest 35.8/52		9998671	
8		2	Snap ring half 300		369512	
9		1	Retaining ring 300		369513	
10	◆ ★	2	O-ring		369525	
11	◆	1	Cylinder 300		370503	
12		1	Snap ring flange 300		370511	
13	◆ ★	1	O-ring		9974118	
14		1	Support ring 34/50-300		369518	
15	◆ ★	3	Sealing collar PE 34/50		369523	
16	◆ ★	2	Sealing collar L 34/50		369922	
16	◆ ★	2	Sealing collar TG 34/50	369522		
16	◆ ★	2	Sealing collar T 34/50			369900
17		1	Pressure ring 34/50		369519	
18	◆ ★	1	Spirawave, crest-to-crest 35.8/52		9998671	
19	◆	1	Valve seat outlet 300		369510	
20	◆ ★	1	O-ring		369528	

◆ = Wearing part

★ = Included in service set

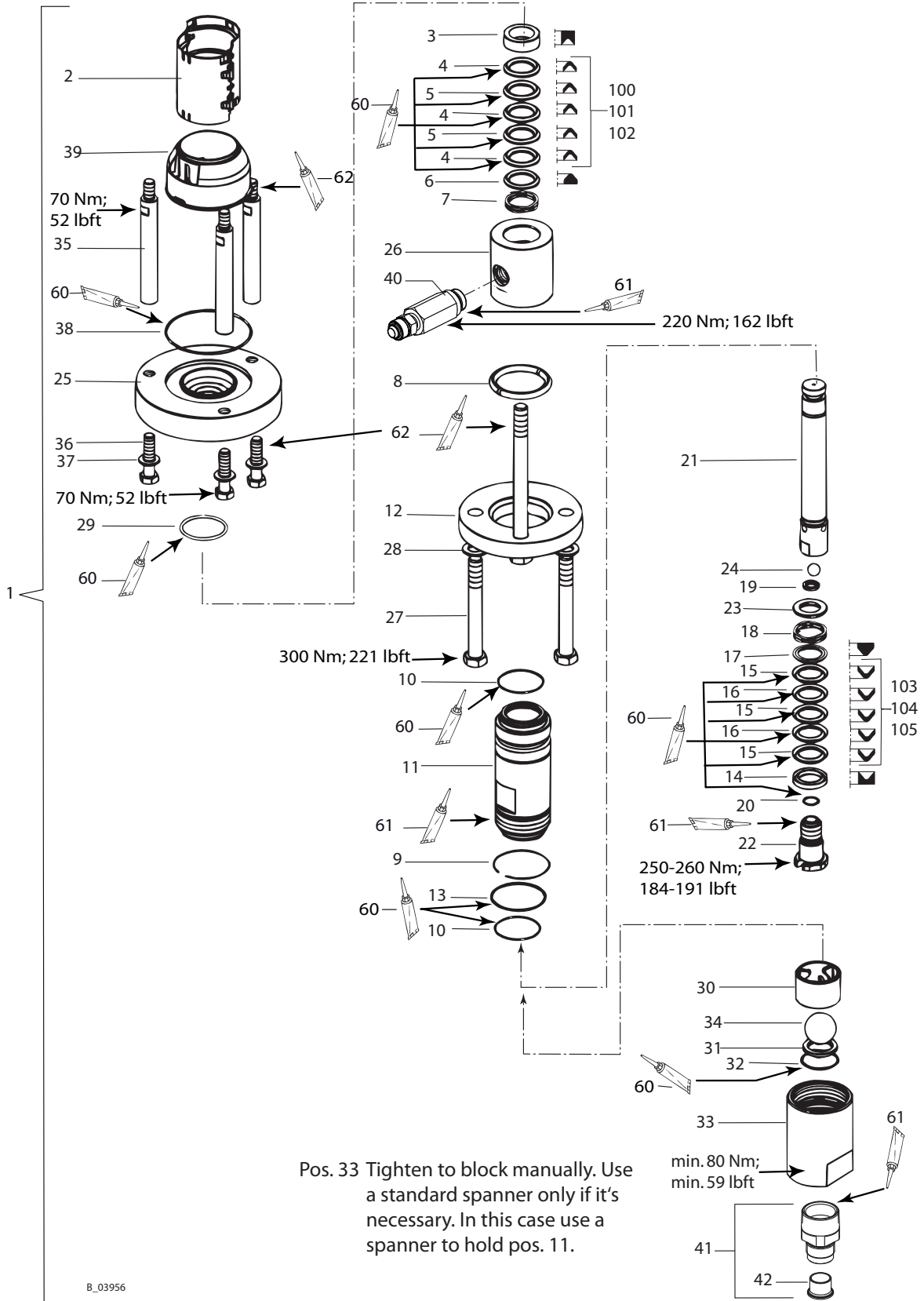

Pos. 33 Tighten to block manually. Use a standard spanner only if it's necessary. In this case use a spanner to hold pos. 11.

B_03956

Fluid sections spare parts list

Pos	K	Stk	Designation	300 cm ³	300 cm ³	300 cm ³
				PE/TG	PE/L	PE/T
				Order No.	Order No.	Order No.
21	◆	1	Piston 300		370505	
22		1	Valve screw 300		370506	
23		1	Shoulder ring 300		370514	
24	◆ ★	1	Ball		9941505	
25		1	Connecting flange		370501	
26		1	Tube 300		370502	
27		4	Hexagon bolt		9907210	
28		4	Washer		9920110	
29	◆ ★	1	O-ring		9974117	
30	◆ ★	1	Ball guide inlet 300		369507	
31	◆	1	Valve seat inlet 300		369509	
32	◆ ★	1	O-ring		369527	
33		1	Inlet housing 300		370504	
34	◆ ★	1	Ball		9943086	
35		3	Threaded bolt M16x169		370533	
36		3	Hexagon bolt		9907209	
37		3	Washer		9925011	
38	◆ ★	1	O-ring		9974116	
39		1	Separating oil cup stroke 150		368531	
40		1	Rotary connection G3/4"		2329923	
41		1	Fitting DF-MM-R1½"-M36-PN15-SSt		2329563	
42		1	Sealing sleeve		2329898	
60		1	Mobilux EP 2 grease		9998808	
61		1	Anti-sieze paste tube		9992609	
62		1	Molykote DX grease		9992616	

Packing, upper:

100	◆	1	Packing PE/L, complete		368993	
101	◆	1	Packing PE/T, complete			368992
102	◆	1	Packing PE/TG, complete	368991		

Packing, lower:

103	◆	1	Packing PE/L, complete		369993	
104	◆	1	Packing PE/T, complete			369992
105	◆	1	Packing PE/TG, complete	369991		

Service sets:

			Service set pump 300 ccm PE+L		370989	
			Service set pump 300 ccm PE+TG	369990		
			Service set pump 300 ccm PE+T			369964

◆ = Wearing part

★ = Included in service set

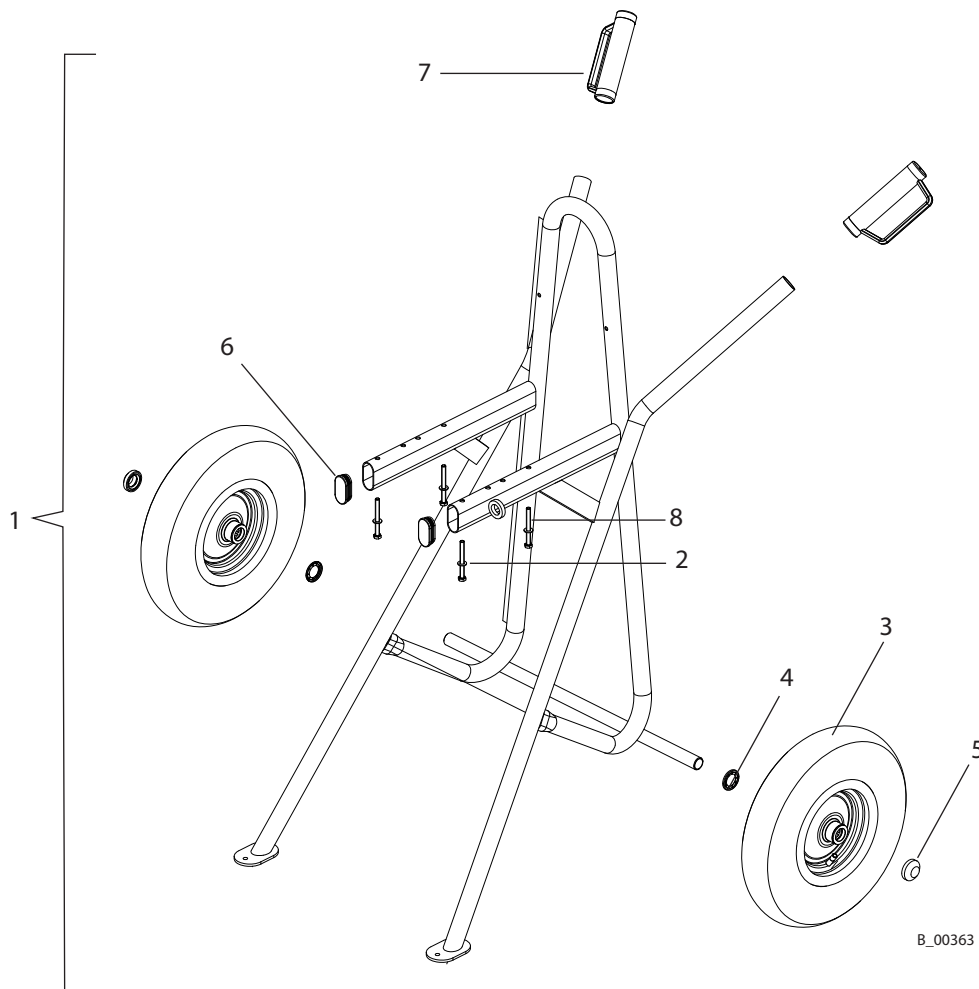
11.5 "HEAVY DUTY" TROLLEY

Pos	K	Stk	Designation	Order No.
1		1	Trolley, heavy duty	369024
2		4	Washer, DIN125, A6.4 or A8.4	9920102
3	◆	2	Wheel	9998892
4		2	Holding ring	9998894
5		2	Quick fastener	9998895
6		2	Plug black	--
7	◆	2	Handle with hand protection	9998893
8		4	Hexagon screw DIN931 M6x75 or M8x80	9900151

◆ = Wearing parts

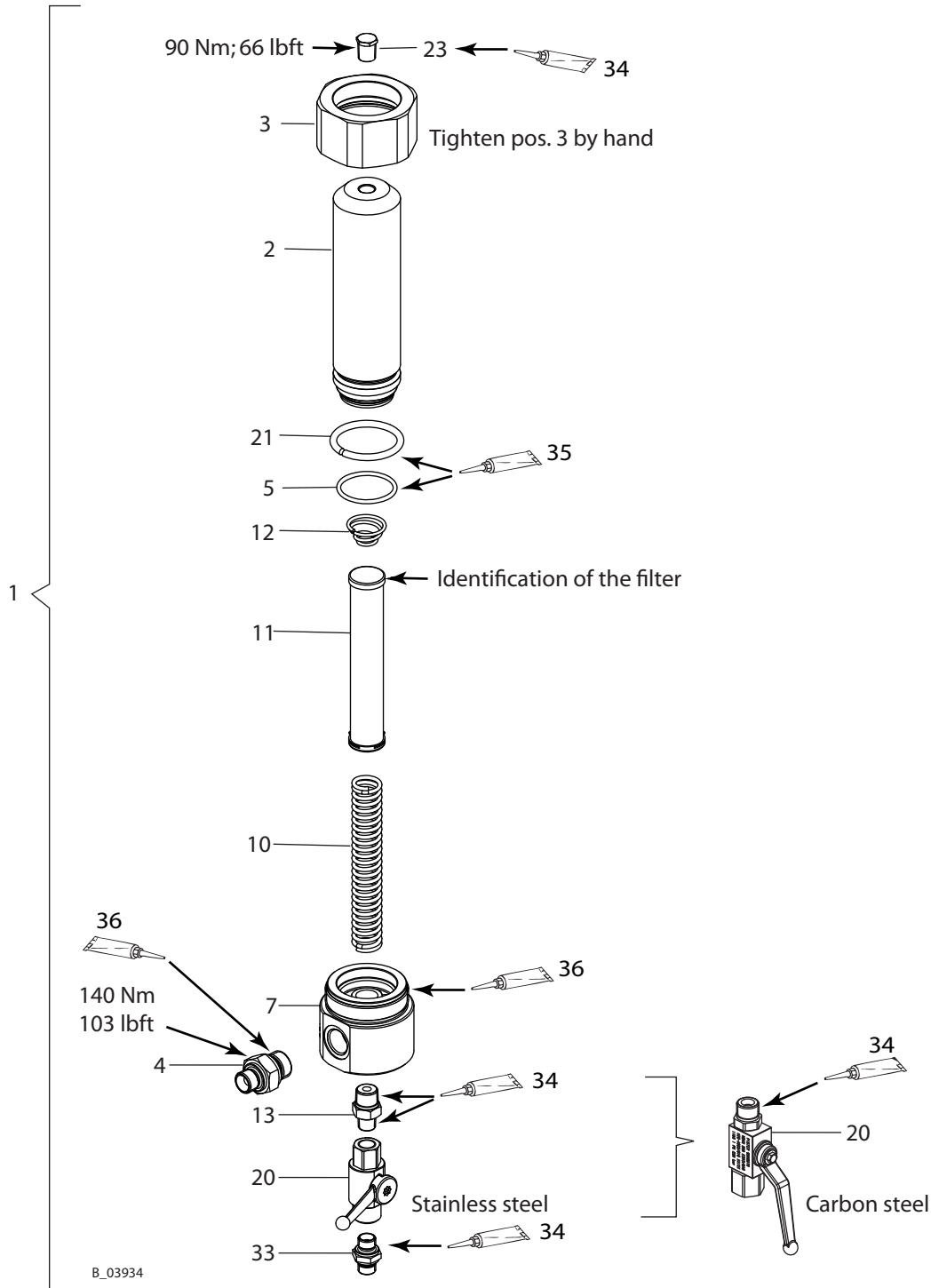

11.6 HIGH-PRESSURE FILTER (UP TO 530 BAR; 7687 PSI)



				Ball valve version in:	
Pos	K	Stk	Designation	Stainless steel	Carbon steel
				Order No.	Order No.
1		1	HP filter DN12-PN530, complete	2329025	2335334
2		1	Filter housing	2324542	
3		1	Union nut	2324543	
4		1	Fitting-DF-MM-G1/2-G3/8-PN530-SSt	2330780	
5	◆	1	O-ring	9955863	
7		1	Distribution housing for ball valve	2324670	
10		1	Filter support	9894245	
11	◆	1	Filter sieve *		
	◆ ●		* Filter sieve 200	295721	
	◆		* Filter sieve 100	3514068	
	◆ ●		* Filter sieve 50	3514069	
	◆ ●		* Filter sieve 20	291564	
12	◆	1	Cone spring	3514058	
13		1	Fitting-DF-MM-R3/8-R1/4-PN530-SSt	2328291	
20	◆	1	Ball valve	2330156	9998679
21		1	Pressure ring d45	2325562	
23		1	Hexagon plug	2323718	
33		1	Double connection	3204611	2325826
34		1	Loctite 542 50 ml; 50 cc	9992831	
35		1	Mobilux EP 2 grease	9998808	
36		1	Anti-sieze paste tube	9992609	

◆ = Wearing parts

● = Not part of the standard equipment but available as a special accessory.

	 WARNING
	<p>Incorrect maintenance/repair! Danger to life and equipment damage.</p> <p>→ Only a WAGNER service center or a suitably trained person may carry out repairs and replace parts.</p> <p>→ Only repair and replace parts that are listed in the chapter "Spare Parts Catalogue" and that are assigned to the device.</p> <p>→ Before all work on the device and in the event of work interruptions:</p> <ul style="list-style-type: none"> - Disconnect the control unit from the mains. - Relieve the pressure from the spray gun and device. - Secure the spray gun against actuation. <p>→ Always follow the operating and service manuals at all times when carrying out work.</p>

12 GUARANTEE AND CONFORMITY DECLARATIONS

12.1 IMPORTANT NOTES REGARDING PRODUCT LIABILITY

As a result of an EC regulation effective from January 1, 1990, the manufacturer shall only be liable for his product if all parts originate from him or are approved by him, and if the devices are properly mounted, operated and maintained.

The manufacturer will not be held liable or will only be held partially liable if third-party accessories or spare parts have been used.

With genuine WAGNER accessories and spare parts, you have the guarantee that all safety regulations are complied with.

12.2 WARRANTY CLAIM

Full warranty is provided for this device:

We will at our discretion repair or replace free of charge all parts which within 24 months in single-shift, 12 months in 2-shift or 6 months in 3-shift operation from date of receipt by the purchaser are found to be wholly or substantially unusable due to causes prior to the sale, in particular faulty design, defective materials or poor workmanship.

The type of warranty provided is such that the device or individual components of the device are either replaced or repaired as we see fit. The resulting costs, in particular shipping charges, road tolls, labour and material costs will be borne by us except where these costs are increased due to the subsequent shipment of the device to a location other than the address of the purchaser.

We do not provide warranty for damage that has been caused or contributed to for the following reasons:

Unsuitable or improper use, faulty installation or commissioning by the purchaser or a third party, normal wear, negligent handling, defective maintenance, unsuitable coating products, substitute materials and the action of chemical, electrochemical or electrical agents, except when the damage is attributable to us.

Abrasive coating products such as red lead, emulsions, glazes, liquid abrasives, zinc dust paints and so forth reduce the service life of valves, packings, spray guns, nozzles, cylinders, pistons etc. Wear and tear due to such causes are not covered by this warranty.

Components that have not been manufactured by WAGNER are subject to the original warranty of the manufacturer.

Replacement of a component does not extend the period of warranty of the device.

The device should be inspected immediately upon receipt. To avoid losing the warranty, we or the supplier company are to be informed in writing about obvious faults within 14 days upon receipt of the device.

We reserve the right to have the warranty compliance met by a contracting company.

The services provided by this warranty are dependent on evidence being provided in the form of an invoice or delivery note. If the examination discovers that no warranty claim exists, the costs of repairs are charged to the purchaser.

It is clearly stipulated that this warranty claim does not represent any constraint on statutory regulations or regulations agreed to contractually in our general terms and conditions.

12.3 CE DECLARATION OF CONFORMITY

Herewith we declare that the supplied version of
Pneumatic pumps and their spraypacks



Tiger 72-300

comply with the following guidelines:

2006/42/EC	94/9/EC
------------	---------

Applied standards, in particular:

DIN EN ISO 12100: 2011	DIN EN ISO 13732-1: 2008	DIN EN 13463-1: 2009
DIN EN 809: 2012	DIN EN 14462: 2010	DIN EN 13463-5: 2011
DIN EN ISO 4413: 2011	DIN EN 12621: 2011	DIN EN ISO 80079-34: 2012
DIN EN ISO 4414: 2011	DIN EN 1127-1: 2011	

Applied national technical standards and specifications, in particular:

BGR 500 Part 2 Chapter 2.29 and Chapter 2.36	TRBS 2153
--	-----------

Identification:

  II 2G IIB c T3 X

EC Certificate of Conformity

The CE certificate of conformity is enclosed with this product. If needed, further copies can be ordered through your WAGNER dealer by specifying the product name and serial number.

Order number: 2302304

12.4 REFERENCE TO GERMAN REGULATIONS AND GUIDELINES

- a) BGR 500 Part 2, Chapter 2.36 Working with Liquid Ejection Devices
- b) BGR 500 Part 2, Chapter 2.29 Working with Coating Materials
- c) BGR 104 Explosion protection rules
- d) TRBS 2153 Avoiding ignition risks
- e) BGR 180 Equipment for cleaning work pieces with solvents
- f) ZH 1/406 Guidelines for liquid ejection devices
- g) BGI 740 Painting rooms and equipment
- h) Betr.Sich.V. Plant Safety Ordinance

Note: All titles can be ordered from Heymanns Publishing House in Cologne, or they can be found on the Internet.

<p>Germany J. WAGNER GmbH Otto-Lilienthal-Str. 18 Postfach 1120 D- 88677 Markdorf Telephone: +49 7544 5050 Telefax: +49 7544 505200 E-Mail: service.standard@wagner-group.com</p>	<p>Switzerland J. WAGNER AG Industriestrasse 22 Postfach 663 CH- 9450 Altstätten Telephone: +41 (0)71 757 2211 Telefax: +41 (0)71 757 2222 E-Mail: rep-ch@wagner-group.ch</p>
<p>Belgium WSB Finishing Equipment Veilinglaan 56/58 B- 1861 Wolvertem Telephone: +32 (0)2 269 4675 Telefax: +32 (0)2 269 7845 E-Mail: info@wsb-wagner.be / HP www.wsb-wagner.eu</p>	<p>Denmark WAGNER Industrial Solution Scandinavia Viborgvej 100, Skærgær DK- 8600 Silkeborg Telephone: +45 70 200 245 Telefax: +45 86 856 027 E-Mail info@wagner-industri.com</p>
<p>United Kingdom WAGNER Spraytech (UK) Ltd. Haslemere Way Tramway Industrial Estate GB- Banbury, OXON OX16 8TY Telephone: +44 (0)1295 265 353 Telefax: +44 (0)1295 269861 E-Mail: enquiries@wagnerspraytech.co.uk</p>	<p>France J. WAGNER France S.A.R.L. Parc de Gutenberg - Bâtiment F8 8, Voie la Cardon F- 91127 Palaiseau-Cedex Telephone: +33 1 825 011 111 Telefax: +33 1691 946 55 E-Mail: division.solutionsindustrielles@wagner-france.fr</p>
<p>Netherlands WSB Finishing Equipment B.V. De Heldinnenlaan 200 NL- 3543 MB Utrecht Telephone: +31 (0) 30 241 4155 Telefax: +31 (0) 30 241 1787 E-Mail: info@wsb-wagner.nl / HP www.wsb-wagner.eu</p>	<p>Italy WAGNER COLORA S.r.l Via Fermi, 3 I- 20875 Burago di Molgora (MB) Telephone: +39 039 625021 Telefax: +39 039 6851800 E-Mail: info@wagnercolora.com</p>
<p>Japan WAGNER Spraytech Ltd. 2-35, Shinden Nishimachi J- Daito Shi, Osaka, 574-0057 Telephone: +81 (0) 720 874 3561 Telefax: +81/ (0) 720 874 3426 E-Mail: marketing@wagner-japan.co.jp</p>	<p>Austria J. WAGNER GmbH Otto-Lilienthal-Str. 18 Postfach 1120 D- 88677 Markdorf Telephone: +49 (0) 7544 5050 Telefax: +49 (0) 7544 505200 E-Mail: service.standard@wagner-group.com</p>
<p>Sweden WAGNER Industrial Solutions Scandinavia Skolgatan 61 SE- 568 31 Skillingaryd Telephone: +46 (0) 370 798 30 Telefax: +46 (0) 370 798 48 E-Mail: info@wagner-industri.com</p>	<p>Spain WAGNER Spraytech Iberica S.A. Ctra. N- 340, Km. 1245,4 E- 08750 Molins de Rei (Barcelona) Telephone: +34 (0) 93 680 0028 Telefax: +34 (0) 93 668 0156 E-Mail: info@wagnerspain.com</p>
<p>Czechoslovakia WAGNER s.r.o. Nedasovská Str. 345 15521 Praha 5 - Zlicin Telephone: +42 (0) 2 579 50 412 Telefax: +42 (0)2 579 51 052 E-Mail: info@wagner.cz</p>	<p>USA WAGNER Systems Inc. 300 Airport Road, unit 1 Elgin, IL 60123 USA Telephone: +1 630 503 2400 Telefax: +1 630 503 2377 E-Mail: info@wagnersystemsinc.com</p>

WAGNER



Order No. 2333543

Germany

J. WAGNER GmbH
Otto-Lilienthal-Str. 18
Postfach 1120

D- 88677 Markdorf

Phone +49/ (0)7544 / 5050
Telefax +49/ (0)7544 / 505200
E-mail service.standard@wagner-group.com

Switzerland

J. WAGNER AG
Industriestrasse 22
Postfach 663

CH- 9450 Altstätten

Phone +41/ (0)71 / 757 2211
Telefax +41/ (0)71 / 757 2222

www.wagner-group.com